



# BJ Micro Boring Tools

Strive For Simplicity

**Quick Tool Change**  
in less than 2 minutes





Made in Taiwan













# CATALOGUE











2026-2027

# Contents





 <b>About</b>	<b>1</b>
 <b>Features</b>	<b>3</b>
 <b>Micro Boring Tools</b>	<b>5</b>
 <b>Technical Information</b>	<b>6</b>
 <b>Tool Identification</b>	<b>7</b>

## BJ Tool Specifications

  <b>10 Degree Turning Tools</b>	<b>8</b>
  <b>0 Degree Turning Tools</b>	<b>11</b>
  <b>21 Degree Profiling Tools</b>	<b>13</b>
  <b>50 Degree Turning Tools</b>	<b>15</b>
  <b>50 Degree Turning Tools (Radius Tip)</b>	<b>17</b>

	<b>G</b>	<b>Grooving Tools</b>	<b>19</b>
	<b>GQ</b>	<b>Round Grooving Tools</b>	<b>21</b>
	<b>B</b>	<b>Back Turning Tools</b>	<b>23</b>
	<b>I</b>	<b>Threading Tools</b>	<b>25</b>
	<b>D</b>	<b>Face Grooving Tools</b>	<b>27</b>
	<b>DQ</b>	<b>Round Face Grooving Tools</b>	<b>29</b>
	<b>D</b>	<b>Face Grooving Tools (Customized)</b>	<b>31</b>
	<b>H</b>	<b>Through Coolant - T Tools</b>	<b>33</b>
	<b>H</b>	<b>Through Coolant - UQ Tools</b>	<b>35</b>
	<b>DC</b>	<b>Double Cutting Edge (TT/UU UQUQ)</b>	<b>37</b>
	<b>DH</b>	<b>Double Head Cutting Edge - TT</b>	<b>NEW</b> <b>39</b>

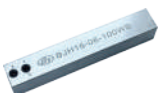
## BJ Patented Toolholders Specifications

<b>■ Holders Classification</b>		<b>41</b>	
<b>D Type</b>		<b>Direct Toolholders</b>	<b>42</b>
<b>B Type</b>		<b>Butterfly Toolholders</b>	<b>45</b>
<b>F Type</b>		<b>Flash Toolholders</b>	<b>48</b>
<b>H Type</b>		<b>Square Shank Toolholders</b>	<b>49</b>
<b>S Type</b>		<b>Special Toolholders</b>	<b>50</b>

## BJ Tool Special Torque Screwdrivers

<b>■ BJ Torque Screwdriver Kits</b>	<b>51</b>
<b>■ BJ Toolholders Screw Specifications Comparison Tablet</b>	<b>59</b>

# About

## ■ BJ: 30 years of CNC lathe precision machining

With our past 30 year's experiences of CNC lathe precision machining, we found out nowadays that the technicians have difficulties in changing tools and skilled Tech-Worker shortage has been an issue. Therefore, we invested in Research and Design (R&D) to assemble our own CNC grinding machine and produce micro boring tools which are our strengths.

BJ systematic boring tools provides higher precision and premium quality. This is perfect for precision machining and it helps reducing labor cost and increasing productivity. Most importantly, we offer our business partner a golden customer service.

## ■ 2023 Active the Cutting Tool Laboratory

BJ set up a fully equipped laboratory to improve tool quality, optimize tool design, test tool life, and demonstrate BJ's internal cutting tools to customers. To accurately test and optimize the experimental process, BJ cooperates with the Academy for Academia and Industry Collaboration.

In terms of equipment aspect, BJ purchased Citizen L20E-2M8 CNC Swiss type machine equipped with High Pressure Coolant Through.

All cutting tools in BJ cutting tool laboratory are screwed with BJ Tool Special Torque Screwdrivers for standardization control to eliminate human factors and cause unstable tool life, poor production utilization etc. negative effects.

Visitors can fully understand BJ cutting tools practical application by visiting BJ cutting tool laboratory, including Turning Tool, Grooving Tool, Threading Tool, Face Grooving Tool.

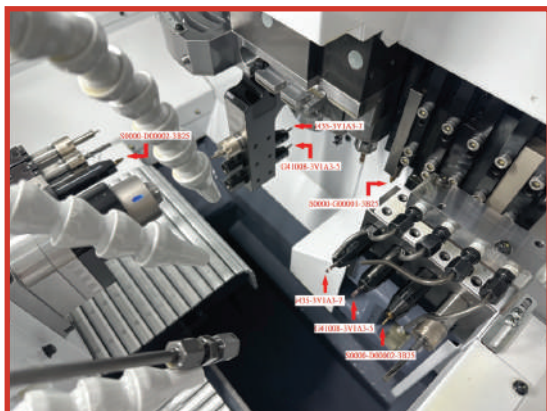

## ■ Why Customers Trust BJ Tools

---

### **24H** Fast Response

2D tool drawing and quotation provided within **24 working hours** for standard designs.

### **72H** Advanced Support

3D tool design and quotation delivered within **72 working hours** for customized developments.

### **70%** New Project Success Rate

Approximately **70%** of new development projects are successfully converted into confirmed orders.

### **75%** Optimization Success Rate

Around **75%** of tool optimization requests result in validated and adopted solutions.

### **90/100** First-Use Satisfaction

End-user feedback consistently reflects a **90/100 satisfaction score** after initial use.

### **90%** Repeat Usage Rate

Over **90%** of end users continue using BJ Tools after trial evaluation.

## ■ Proven Track Record

---

- ▶▶ **1,000+ customers** in Taiwan, **1,000+ overseas**
- ▶▶ **10,000+ custom tool records**
- ▶▶ Custom tools & toolholders for **CNC Swiss & CNC lathes**
- ▶▶ Experience with **Citizen, Star, Tsugami, Nomura, Tornos, Miyano, Nakamura-Tome, Hurco, DMG MORI**



# Features

## ■ BJ Tools & Holders Special Features

### Tool locking procedure:

- ▶▶ Find the right angle, align the tool accordingly and insert until the end.
- ▶▶ Slightly lock the rear screw.
- ▶▶ Tightly lock the front screw.
- ▶▶ Firmly relock the rear screw.

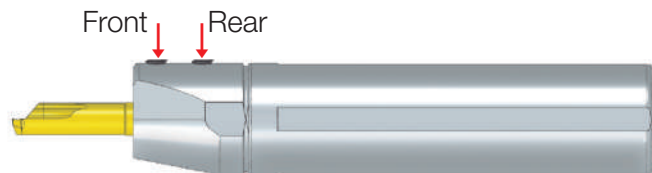

View Full Video on YouTube ▶

**Our Tools are easy to lock and can be changed without removing the holders.**

## ■ Understanding Reference Plane

To facilitate easy tool change, regardless of the brands and different machine types, we designed 2 types of reference plane.



- ▶▶ **0°** : Reference plane and tip are on the same side.

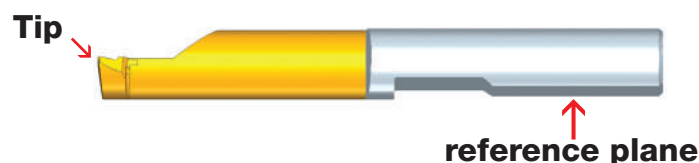

- ▶▶ **180°** : Reference plane and tip are opposite sides.  
( top and bottom )

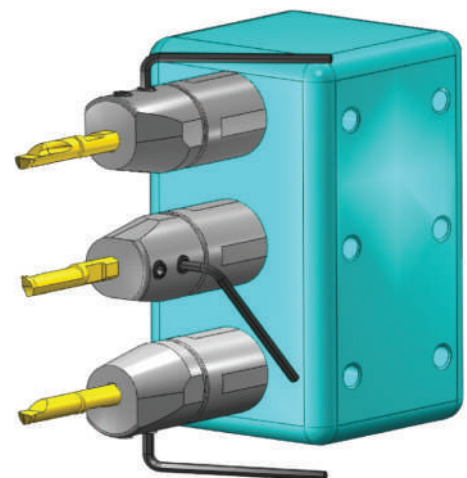

View Full Video on YouTube ▶

## 6 Key Features

### ▶▶ High Repeatability $\pm 0.02$ mm

Foolproof design ensures accurate and stable repeat positioning.

### ▶▶ Japanese Tungsten Carbide Rods

Consistent performance with stable, high-quality raw material.

### ▶▶ 10 Coating Options

Including TiAlN, TiSiN, AlTiSiN, AlTiCrN, AlCrSiN, ZrAlTiSiN, DLC, and ta-C.

### ▶▶ 3-Step Quick Change

Laser-marked 1–2–3 on toolholders for easy and correct tool replacement.

### ▶▶ Coolant-Through Design

All standard toolholders feature coolant-through capability.

Coolant-through tools are also available upon request.

### ▶▶ Standard & Custom Solutions

Fast lead times for both standard products and customized tools.

▼ YouTube Link

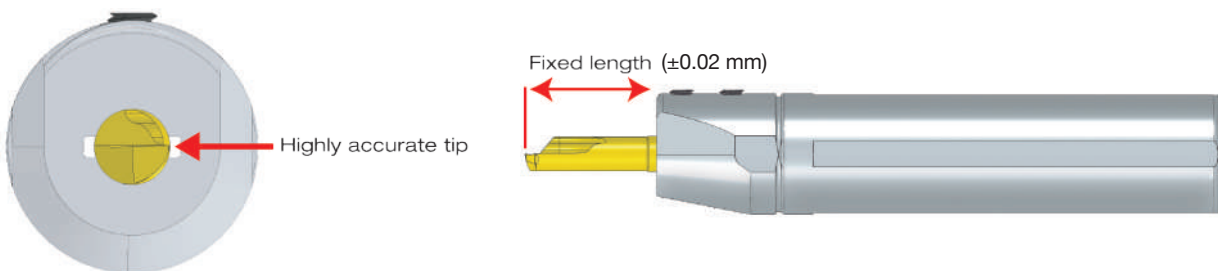
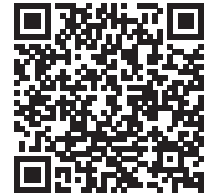

**Most Prominent Features :**

**Easy for beginners to use, preventing and solving technical problems.**

# Micro Boring Tools

## ■ BJ Boring Tools Series

### ▶▶ Shank Diameter Options

Φ3 / Φ4 / Φ5 / Φ6 / Φ8  
Custom: Φ2 / Φ7 / Φ10

### ▶▶ Chip Breaker Types

V – Chip Breaker  
P – Flat

### ▶▶ Cutting Length (L/D) Ratios

Standard: 3x / 4x / 5x / 6x / 7x  
Custom lengths available on request

### ▶▶ Coating Options

TiAlN, TiSiN, AlTiSiN, AlTiCrN, AlCrSiN, ZrAlTiSiN, DLC, ta-C

### ▶▶ Radius Tip

Standard: R0.05 / R0.1 / R0.2  
Custom radius available

### ▶▶ Applications Covered

Turning · Profiling · Grooving  
Face Grooving · Threading · Forming

### ▶▶ Industry Applications

Aerospace · Medical · Automotive  
Electronics · Semiconductor



**T** 10 Degree Turning Tools



**I** Threading Tools



**TA** 0 Degree Turning Tools



**D** Face Grooving Tools



**UT** 21 Degree Profiling Tools



**DQ** Round Face Grooving Tools



**U** 50 Degree Turning Tools



**D** Face Grooving Tools  
(Customized)



**UQ** 50 Degree Turning Tools  
(Radius Tip)



**H** Through Coolant  
- T Tools



**G** Grooving Tools



**H** Through Coolant  
- UQ Tools



**GQ** Round Grooving Tools



**DC** Double Cutting Edge  
(TT/UU/UQUQ)



**B** Back Turning Tools



**DH** Double Head  
Cutting Edge - TT

## Recommended Speed And Feedrate

Workpiece Material	Cutting Speed (m/min)	Feed Rate (mm/rev)	Chipbreaker (V/P)
Bronze	>100m	F0.03-F0.08	P
Aluminum Alloy	>100m	F0.03-F0.08	P
S15C	60m-120m	F0.03-F0.05	V
S45C	50m-60m	F0.03-F0.05	V
12L14	>100m	F0.03-F0.05	P
12L15	80m-100m	F0.03-F0.05	P
SUS303	50m-60m	F0.03-F0.05	P
SUS304	50m-60m	F0.03-F0.05	V
SUS310	50m-60m	F0.03-F0.05	V
SUS316	50m-60m	F0.03-F0.05	V
SUS420	50m-60m	F0.03-F0.05	V
SCM415	50m-60m	F0.03-F0.05	V
SCM435	50m-60m	F0.03-F0.05	V
SKD11	40m-50m	F0.03-F0.05	V
A286	40m-50m	F0.03-F0.05	V
INCONEL 718	40m-50m	F0.03-F0.05	V
WASPALLOY	40m-50m	F0.03-F0.05	V

# Tools Identification

## Tools Identification

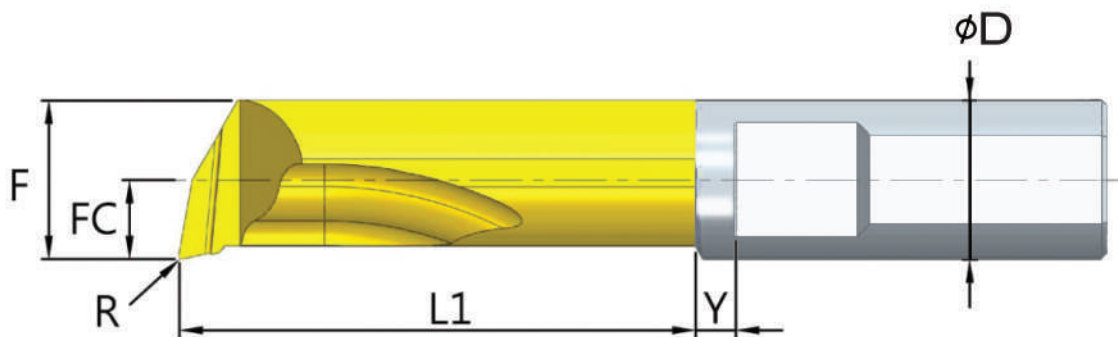
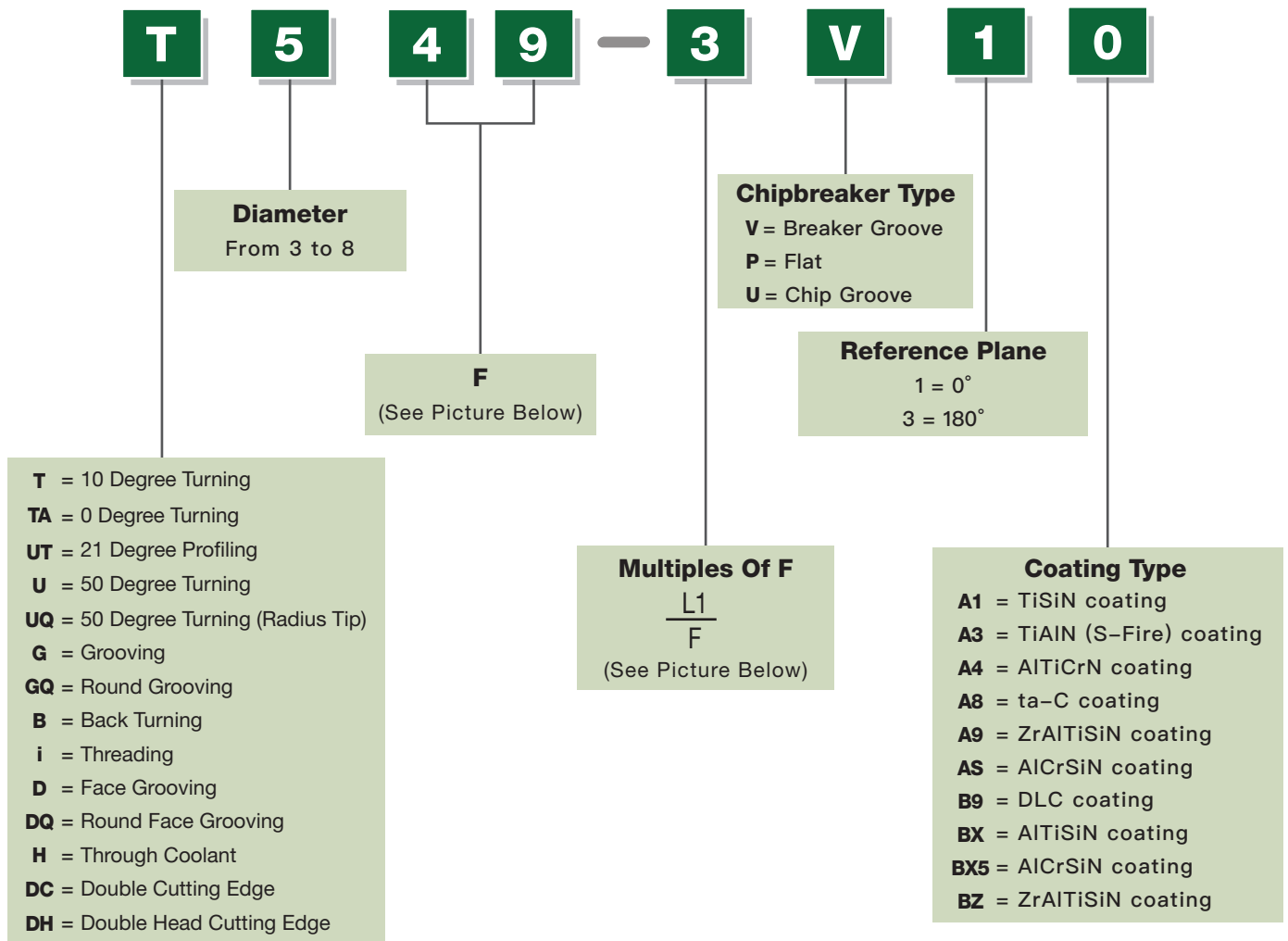

## 10 Degree Turning Tool

- ▶▶ **Specification** | Ø0.6 – Ø8.0 mm, Japanese tungsten carbide.
- ▶▶ **Feature** | For roughing & finishing.
- ▶▶ **Coating** | Swiss coating equipment with European coating targets.

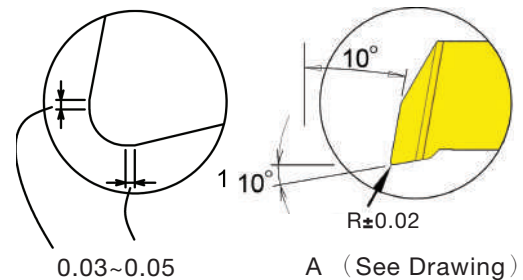
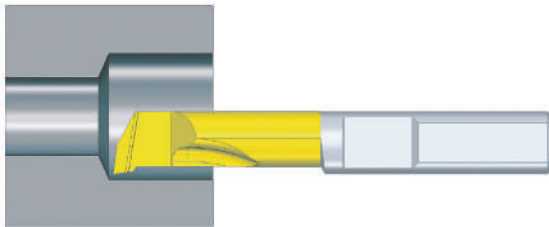

**Tool Numbering** : 3□☆○

- |  |  |
|--|--|
| <p>3 : Multiples of F</p> <p>□ : Chipbreaker Type<br/>V=Breaker Groove<br/>P=Flat</p> <p>☆ : Reference Plane<br/>1=0°<br/>3=180°</p> | <p>○ : Coating Type</p> <p><b>A3</b> = TiAlN (S-Fire) coating<br/><b>A4</b> = AlTiCrN coating<br/><b>A8</b> = ta-C coating<br/><b>A9</b> = ZrAlTiSiN coating<br/><b>AS</b> = AlCrSiN coating</p> <p><b>A1</b> = TiSiN coating<br/><b>B9</b> = DLC coating<br/><b>BX</b> = AlTiSiN coating<br/><b>BX5</b> = AlCrSiN coating<br/><b>BZ</b> = ZrAlTiSiN coating</p> |
|--|--|



**V** Breaker Groove



**Reference Plane 0°**



**P** Flat



**Reference Plane 180°**

### Remark

- Item numbers are based on 0° reference plane, V chip breaker, and TiAlN(S-Fire) coating.
- Please advise if 180° reference plane, flat type, uncoated, or TiSiN coating is required.
- Full customization available for all dimensions, including F / FC / L1 / L2 / ØD / Tip radius / Front angle, in addition to the standard 10° turning tool.
- Inch dimensions can be manufactured upon request.

# T Tool

## 10 Degree Turning Tool

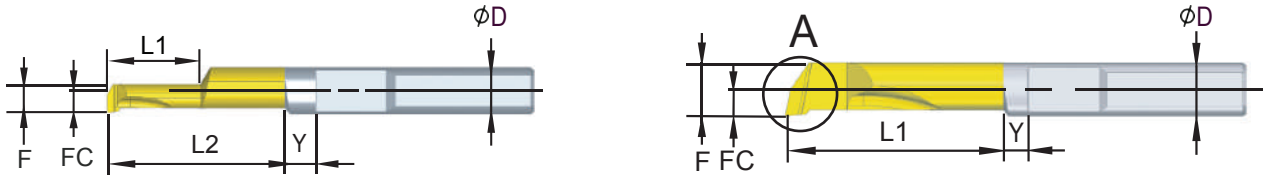

Item Number	D	Minimum Diameter	F	FC	R	Multiples	L1	L2	Y	Chipbreaker	Reference Plane (degree)	Coating Type
T306-4V1A3	3	0.7	0.6	1.4	0.03	4	2.7	4.7	2.3	✓	0	TiAlN
T310-4V1A3	3	1.2	1	1.4	0.03	4	4.5	6.2	2.8	✓	0	TiAlN
T318-3V1A3	3	2	1.8	1.4	0.05	3	6	7	4	✓	0	TiAlN
T318-4V1A3	3	2	1.8	1.4	0.05	4	8	10	3.4	✓	0	TiAlN
T318-5V1A3	3	2	1.8	1.4	0.05	5	10	12	4	✓	0	TiAlN
T318-6V1A3	3	2	1.8	1.4	0.05	6	12	12	4	✓	0	TiAlN
T318-7V1A3	3	2	1.8	1.4	0.05	7	14	17	3	✓	0	TiAlN
T329-3V1A3	3	3.2	2.9	1.4	0.1	3	9	-	2	✓	0	TiAlN
T329-4V1A3	3	3.2	2.9	1.4	0.1	4	11.4	-	2	✓	0	TiAlN
T329-5V1A3	3	3.2	2.9	1.4	0.1	5	14	-	2	✓	0	TiAlN
T329-6V1A3	3	3.2	2.9	1.4	0.1	6	18	-	2	✓	0	TiAlN
T329-7V1A3	3	3.2	2.9	1.4	0.1	7	21	-	2	✓	0	TiAlN
T439-3V1A3	4	4.2	3.9	1.9	0.1	3	11	-	2	✓	0	TiAlN
T439-4V1A3	4	4.2	3.9	1.9	0.1	4	14.5	-	2	✓	0	TiAlN
T439-5V1A3	4	4.2	3.9	1.9	0.1	5	18	-	2	✓	0	TiAlN
T439-6V1A3	4	4.2	3.9	1.9	0.1	6	23	-	2	✓	0	TiAlN
T439-7V1A3	4	4.2	3.9	1.9	0.1	7	27	-	2	✓	0	TiAlN
T549-3V1A3	5	5.2	4.9	2.4	0.1	3	15	-	2	✓	0	TiAlN
T549-4V1A3	5	5.2	4.9	2.4	0.1	4	19	-	2	✓	0	TiAlN
T549-5V1A3	5	5.2	4.9	2.4	0.1	5	23	-	2	✓	0	TiAlN
T549-6V1A3	5	5.2	4.9	2.4	0.1	6	30	-	2	✓	0	TiAlN
T549-7V1A3	5	5.2	4.9	2.4	0.1	7	35	-	2	✓	0	TiAlN
T659-3V1A3	6	6.2	5.9	2.9	0.1	3	17	-	2	✓	0	TiAlN
T659-4V1A3	6	6.2	5.9	2.9	0.1	4	23	-	2	✓	0	TiAlN
T659-5V1A3	6	6.2	5.9	2.9	0.1	5	28	-	2	✓	0	TiAlN
T659-6V1A3	6	6.2	5.9	2.9	0.1	6	34	-	2	✓	0	TiAlN
T659-7V1A3	6	6.2	5.9	2.9	0.1	7	42	-	2	✓	0	TiAlN
T879-3V1A3	8	8.2	7.9	3.9	0.1	3	22	-	2	✓	0	TiAlN
T879-4V1A3	8	8.2	7.9	3.9	0.1	4	30	-	2	✓	0	TiAlN
T879-5V1A3	8	8.2	7.9	3.9	0.1	5	38	-	2	✓	0	TiAlN
T879-6V1A3	8	8.2	7.9	3.9	0.1	6	46	-	2	✓	0	TiAlN
T879-7V1A3	8	8.2	7.9	3.9	0.1	7	54	-	2	✓	0	TiAlN

# T Tool

## 10 Degree Turning Tool (T-R0.2 Tool)

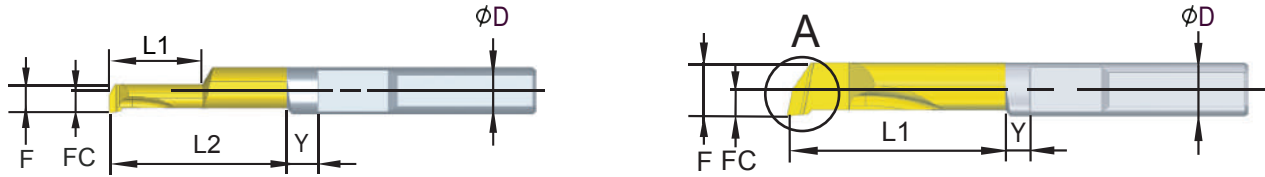

Item Number	D	Minimum Diameter	F	FC	R	Multiples	L1	L2	Y	Chipbreaker	Reference Plane (degree)	Coating Type
T318-3V1A3-R10	3	2	1.8	1.4	0.1	3	6	7	4	✓	0	TiAlN
T318-4V1A3-R10	3	2	1.8	1.4	0.1	4	8	10	3.4	✓	0	TiAlN
T318-5V1A3-R10	3	2	1.8	1.4	0.1	5	10	12	4	✓	0	TiAlN
T329-3V1A3-R20	3	3.2	2.9	1.4	0.2	3	9	-	2	✓	0	TiAlN
T329-4V1A3-R20	3	3.2	2.9	1.4	0.2	4	11.4	-	2	✓	0	TiAlN
T329-5V1A3-R20	3	3.2	2.9	1.4	0.2	5	14	-	2	✓	0	TiAlN
T329-6V1A3-R20	3	3.2	2.9	1.4	0.2	6	18	-	2	✓	0	TiAlN
T329-7V1A3-R20	3	3.2	2.9	1.4	0.2	7	21	-	2	✓	0	TiAlN
T439-3V1A3-R20	4	4.2	3.9	1.9	0.2	3	11	-	2	✓	0	TiAlN
T439-4V1A3-R20	4	4.2	3.9	1.9	0.2	4	14.5	-	2	✓	0	TiAlN
T439-5V1A3-R20	4	4.2	3.9	1.9	0.2	5	18	-	2	✓	0	TiAlN
T439-6V1A3-R20	4	4.2	3.9	1.9	0.2	6	23	-	2	✓	0	TiAlN
T439-7V1A3-R20	4	4.2	3.9	1.9	0.2	7	27	-	2	✓	0	TiAlN
T549-3V1A3-R20	5	5.2	4.9	2.4	0.2	3	15	-	2	✓	0	TiAlN
T549-4V1A3-R20	5	5.2	4.9	2.4	0.2	4	19	-	2	✓	0	TiAlN
T549-5V1A3-R20	5	5.2	4.9	2.4	0.2	5	23	-	2	✓	0	TiAlN
T549-6V1A3-R20	5	5.2	4.9	2.4	0.2	6	30	-	2	✓	0	TiAlN
T549-7V1A3-R20	5	5.2	4.9	2.4	0.2	7	35	-	2	✓	0	TiAlN
T659-3V1A3-R20	6	6.2	5.9	2.9	0.2	3	17	-	2	✓	0	TiAlN
T659-4V1A3-R20	6	6.2	5.9	2.9	0.2	4	23	-	2	✓	0	TiAlN
T659-5V1A3-R20	6	6.2	5.9	2.9	0.2	5	28	-	2	✓	0	TiAlN
T659-6V1A3-R20	6	6.2	5.9	2.9	0.2	6	34	-	2	✓	0	TiAlN
T659-7V1A3-R20	6	6.2	5.9	2.9	0.2	7	42	-	2	✓	0	TiAlN
T879-3V1A3-R20	8	8.2	7.9	3.9	0.2	3	22	-	2	✓	0	TiAlN
T879-4V1A3-R20	8	8.2	7.9	3.9	0.2	4	30	-	2	✓	0	TiAlN
T879-5V1A3-R20	8	8.2	7.9	3.9	0.2	5	38	-	2	✓	0	TiAlN
T879-6V1A3-R20	8	8.2	7.9	3.9	0.2	6	46	-	2	✓	0	TiAlN
T879-7V1A3-R20	8	8.2	7.9	3.9	0.2	7	54	-	2	✓	0	TiAlN

# TA Tool

## 0 Degree Turning Tool

- ▶▶ **Specification** |  $\varnothing 0.6 - \varnothing 8.0$  mm, Japanese tungsten carbide.
- ▶▶ **Feature** | For roughing & finishing.
- ▶▶ **Coating** | Swiss coating equipment with European coating targets.

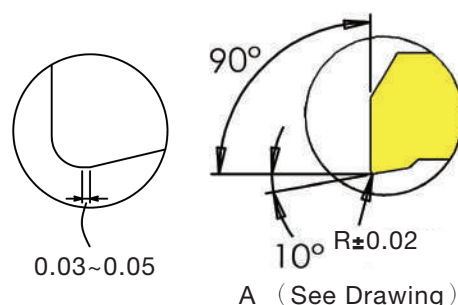
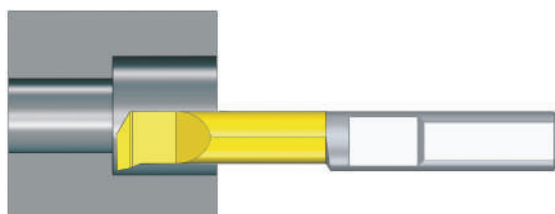

**Tool Numbering** : 3□☆○

- |  |   |                                    |                           |                             |                         |                          |                             |                               |                              |                             |                               |
|--|---|------------------------------------|---------------------------|-----------------------------|-------------------------|--------------------------|-----------------------------|-------------------------------|------------------------------|-----------------------------|-------------------------------|
| <p>3 : Multiples of F</p> <p>□ : Chipbreaker Type<br/>V=Breaker Groove<br/>P=Flat</p> <p>☆ : Reference Plane<br/>1=0°<br/>3=180°</p> | <p>○ : Coating Type</p> <table border="0"> <tr> <td><b>A3</b> = TiAlN (S-Fire) coating</td> <td><b>A1</b> = TiSiN coating</td> </tr> <tr> <td><b>A4</b> = AlTiCrN coating</td> <td><b>B9</b> = DLC coating</td> </tr> <tr> <td><b>A8</b> = ta-C coating</td> <td><b>BX</b> = AlTiSiN coating</td> </tr> <tr> <td><b>A9</b> = ZrAlTiSiN coating</td> <td><b>BX5</b> = AlCrSiN coating</td> </tr> <tr> <td><b>AS</b> = AlCrSiN coating</td> <td><b>BZ</b> = ZrAlTiSiN coating</td> </tr> </table> | <b>A3</b> = TiAlN (S-Fire) coating | <b>A1</b> = TiSiN coating | <b>A4</b> = AlTiCrN coating | <b>B9</b> = DLC coating | <b>A8</b> = ta-C coating | <b>BX</b> = AlTiSiN coating | <b>A9</b> = ZrAlTiSiN coating | <b>BX5</b> = AlCrSiN coating | <b>AS</b> = AlCrSiN coating | <b>BZ</b> = ZrAlTiSiN coating |
| <b>A3</b> = TiAlN (S-Fire) coating   | <b>A1</b> = TiSiN coating   |                                    |                           |                             |                         |                          |                             |                               |                              |                             |                               |
| <b>A4</b> = AlTiCrN coating  | <b>B9</b> = DLC coating   |                                    |                           |                             |                         |                          |                             |                               |                              |                             |                               |
| <b>A8</b> = ta-C coating   | <b>BX</b> = AlTiSiN coating   |                                    |                           |                             |                         |                          |                             |                               |                              |                             |                               |
| <b>A9</b> = ZrAlTiSiN coating  | <b>BX5</b> = AlCrSiN coating  |                                    |                           |                             |                         |                          |                             |                               |                              |                             |                               |
| <b>AS</b> = AlCrSiN coating  | <b>BZ</b> = ZrAlTiSiN coating   |                                    |                           |                             |                         |                          |                             |                               |                              |                             |                               |



**V** Breaker Groove



**Reference Plane 0°**



**P** Flat



**Reference Plane 180°**

### Remark

- Item numbers are based on 0° reference plane, V chip breaker, and TiAlN(S-Fire) coating.
- Please advise if 180° reference plane, flat type, uncoated, or TiSiN coating is required.
- Full customization available for all dimensions, including F / FC / L1 / L2 /  $\varnothing D$  / Tip radius / Front angle, in addition to the standard 0° turning tool.
- Inch dimensions can be manufactured upon request.

## 0 Degree Turning Tool

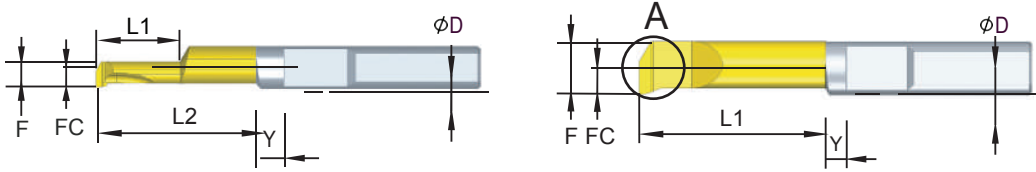

Item Number	D	Minimum Diameter	F	FC	R	Multiples	L1	L2	Y	Chipbreaker	Reference Plane (degree)	Coating Type
TA306-4V1A3	3	0.7	0.6	1.4	0.03	4	2.7	5	2	✓	0	TiAlN
TA310-4V1A3	3	1.2	1	1.4	0.03	4	4.5	6.2	2.8	✓	0	TiAlN
TA318-3V1A3	3	2	1.8	1.4	0.05	3	6	7	4	✓	0	TiAlN
TA318-4V1A3	3	2	1.8	1.4	0.05	4	8	10.1	3.3	✓	0	TiAlN
TA318-5V1A3	3	2	1.8	1.4	0.05	5	10	12.5	3.5	✓	0	TiAlN
TA318-6V1A3	3	2	1.8	1.4	0.05	6	12	12	4	✓	0	TiAlN
TA318-7V1A3	3	2	1.8	1.4	0.05	7	14	17	3	✓	0	TiAlN
TA329-3V1A3	3	3.2	2.9	1.4	0.1	3	9	-	2	✓	0	TiAlN
TA329-4V1A3	3	3.2	2.9	1.4	0.1	4	11.4	-	2	✓	0	TiAlN
TA329-5V1A3	3	3.2	2.9	1.4	0.1	5	14	-	2	✓	0	TiAlN
TA329-6V1A3	3	3.2	2.9	1.4	0.1	6	18	-	2	✓	0	TiAlN
TA329-7V1A3	3	3.2	2.9	1.4	0.1	7	21	-	2	✓	0	TiAlN
TA439-3V1A3	4	4.2	3.9	1.9	0.1	3	11	-	2	✓	0	TiAlN
TA439-4V1A3	4	4.2	3.9	1.9	0.1	4	14.5	-	2	✓	0	TiAlN
TA439-5V1A3	4	4.2	3.9	1.9	0.1	5	18	-	2	✓	0	TiAlN
TA439-6V1A3	4	4.2	3.9	1.9	0.1	6	23	-	2	✓	0	TiAlN
TA439-7V1A3	4	4.2	3.9	1.9	0.1	7	27	-	2	✓	0	TiAlN
TA549-3V1A3	5	5.2	4.9	2.4	0.1	3	15	-	2	✓	0	TiAlN
TA549-4V1A3	5	5.2	4.9	2.4	0.1	4	19	-	2	✓	0	TiAlN
TA549-5V1A3	5	5.2	4.9	2.4	0.1	5	23	-	2	✓	0	TiAlN
TA549-6V1A3	5	5.2	4.9	2.4	0.1	6	30	-	2	✓	0	TiAlN
TA549-7V1A3	5	5.2	4.9	2.4	0.1	7	35	-	2	✓	0	TiAlN
TA659-3V1A3	6	6.2	5.9	2.9	0.1	3	17	-	2	✓	0	TiAlN
TA659-4V1A3	6	6.2	5.9	2.9	0.1	4	23	-	2	✓	0	TiAlN
TA659-5V1A3	6	6.2	5.9	2.9	0.1	5	28	-	2	✓	0	TiAlN
TA659-6V1A3	6	6.2	5.9	2.9	0.1	6	34	-	2	✓	0	TiAlN
TA659-7V1A3	6	6.2	5.9	2.9	0.1	7	42	-	2	✓	0	TiAlN

## 21 Degree Profiling Tool

- ▶▶ **Specification** |  $\varnothing 0.6 - \varnothing 8.0$  mm, Japanese tungsten carbide.
- ▶▶ **Feature** | For roughing & finishing.
- ▶▶ **Coating** | Swiss coating equipment with European coating targets.

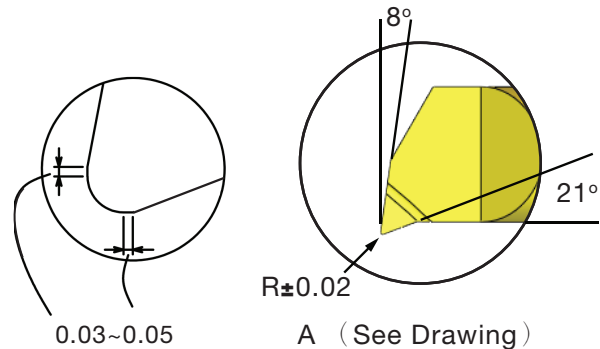
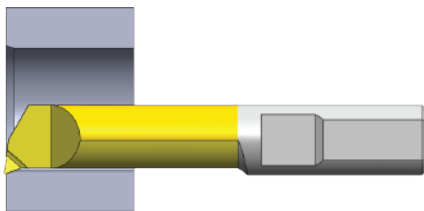

**Tool Numbering** : 3 □ ☆ ○

- |  |  |
|--|--|
| <p>3 : Multiples of F</p> <p>□ : Chipbreaker Type<br/>V=Breaker Groove<br/>P=Flat</p> <p>☆ : Reference Plane<br/>1=0°<br/>3=180°</p> | <p>○ : Coating Type</p> <p><b>A3</b> = TiAlN (S-Fire) coating<br/><b>A4</b> = AlTiCrN coating<br/><b>A8</b> = ta-C coating<br/><b>A9</b> = ZrAlTiSiN coating<br/><b>AS</b> = AlCrSiN coating</p> <p><b>A1</b> = TiSiN coating<br/><b>B9</b> = DLC coating<br/><b>BX</b> = AlTiSiN coating<br/><b>BX5</b> = AlCrSiN coating<br/><b>BZ</b> = ZrAlTiSiN coating</p> |
|--|--|



V Breaker Groove / Reference Plane 0°

### Remark

- Item numbers are based on 0° reference plane, V chip breaker, and TiAlN(S-Fire) coating.
- Please advise if 180° reference plane, flat type, uncoated, or TiSiN coating is required.
- Full customization available for all dimensions, including F / FC / L1 / L2 /  $\varnothing D$  / Tip radius / Front angle, in addition to the standard 21° profiling tool.
- Inch dimensions can be manufactured upon request.

## 21 Degree Profiling Tool

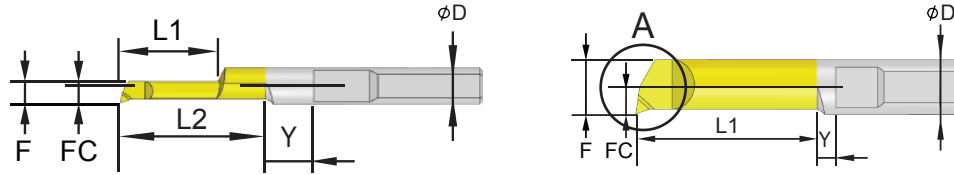

Item Number	D	Minimum Diameter	F	FC	R	Multiples	L1	L2	Y	Chipbreaker	Reference Plane (degree)	Coating Type
UT310-4V1A3	3	1.2	1	1.4	0.03	4	4.5	6.2	2.8	✓	0	TiAlN
UT318-3V1A3	3	2	1.8	1.4	0.05	3	6	7	4	✓	0	TiAlN
UT318-4V1A3	3	2	1.8	1.4	0.05	4	8	10	3.4	✓	0	TiAlN
UT318-5V1A3	3	2	1.8	1.4	0.05	5	10	12	4	✓	0	TiAlN
UT318-6V1A3	3	2	1.8	1.4	0.05	6	12	12	4	✓	0	TiAlN
UT318-7V1A3	3	2	1.8	1.4	0.05	7	14	17	3	✓	0	TiAlN
UT329-3V1A3	3	3.2	2.9	1.4	0.1	3	9	-	2	✓	0	TiAlN
UT329-4V1A3	3	3.2	2.9	1.4	0.1	4	11.4	-	2	✓	0	TiAlN
UT329-5V1A3	3	3.2	2.9	1.4	0.1	5	14	-	2	✓	0	TiAlN
UT329-6V1A3	3	3.2	2.9	1.4	0.1	6	18	-	2	✓	0	TiAlN
UT329-7V1A3	3	3.2	2.9	1.4	0.1	7	21	-	2	✓	0	TiAlN
UT439-3V1A3	4	4.2	3.9	1.9	0.1	3	11	-	2	✓	0	TiAlN
UT439-4V1A3	4	4.2	3.9	1.9	0.1	4	14.5	-	2	✓	0	TiAlN
UT439-5V1A3	4	4.2	3.9	1.9	0.1	5	18	-	2	✓	0	TiAlN
UT439-6V1A3	4	4.2	3.9	1.9	0.1	6	23	-	2	✓	0	TiAlN
UT439-7V1A3	4	4.2	3.9	1.9	0.1	7	27	-	2	✓	0	TiAlN
UT549-3V1A3	5	5.2	4.9	2.4	0.1	3	15	-	2	✓	0	TiAlN
UT549-4V1A3	5	5.2	4.9	2.4	0.1	4	19	-	2	✓	0	TiAlN
UT549-5V1A3	5	5.2	4.9	2.4	0.1	5	23	-	2	✓	0	TiAlN
UT549-6V1A3	5	5.2	4.9	2.4	0.1	6	30	-	2	✓	0	TiAlN
UT549-7V1A3	5	5.2	4.9	2.4	0.1	7	35	-	2	✓	0	TiAlN
UT659-3V1A3	6	6.2	5.9	2.9	0.1	3	17	-	2	✓	0	TiAlN
UT659-4V1A3	6	6.2	5.9	2.9	0.1	4	23	-	2	✓	0	TiAlN
UT659-5V1A3	6	6.2	5.9	2.9	0.1	5	28	-	2	✓	0	TiAlN
UT659-6V1A3	6	6.2	5.9	2.9	0.1	6	34	-	2	✓	0	TiAlN
UT659-7V1A3	6	6.2	5.9	2.9	0.1	7	42	-	2	✓	0	TiAlN

# U Tool

## 50 Degree Turning Tool

- ▶▶ **Specification** |  $\varnothing 1.0 - \varnothing 8.0$  mm, Japanese tungsten carbide.
- ▶▶ **Feature** | For roughing & finishing.
- ▶▶ **Coating** | Swiss coating equipment with European coating targets.

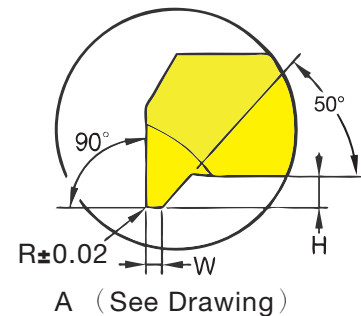
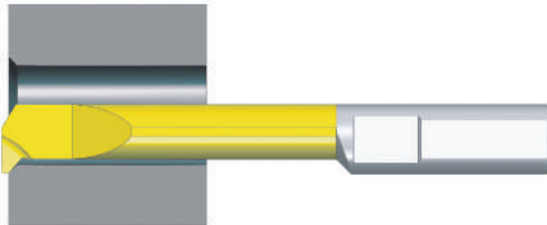

**Tool Numbering** : 3□☆○

- |  |  |
|--|--|
| <p>3 : Multiples of F</p> <p>□ : Chipbreaker Type<br/>V=Breaker Groove<br/>P=Flat</p> <p>☆ : Reference Plane<br/>1=0°<br/>3=180°</p> | <p>○ : Coating Type</p> <p><b>A3</b> = TiAlN (S-Fire) coating<br/><b>A4</b> = AlTiCrN coating<br/><b>A8</b> = ta-C coating<br/><b>A9</b> = ZrAlTiSiN coating<br/><b>AS</b> = AlCrSiN coating</p> <p><b>A1</b> = TiSiN coating<br/><b>B9</b> = DLC coating<br/><b>BX</b> = AlTiSiN coating<br/><b>BX5</b> = AlCrSiN coating<br/><b>BZ</b> = ZrAlTiSiN coating</p> |
|--|--|



**V** Breaker Groove



**Reference Plane 0°**



**P** Flat



**Reference Plane 180°**

### Remark

- Item numbers are based on 0° reference plane, V chip breaker, and TiAlN(S-Fire) coating.
- Please advise if 180° reference plane, flat type, uncoated, or TiSiN coating is required.
- Full customization available for all dimensions, including F / FC / L1 / L2 / W / H /  $\varnothing D$  / Tip radius / Front angle, in addition to the standard 50° front turning + back chamfering tool.
- Inch dimensions can be manufactured upon request.

# U Tool

## 50 Degree Turning Tool

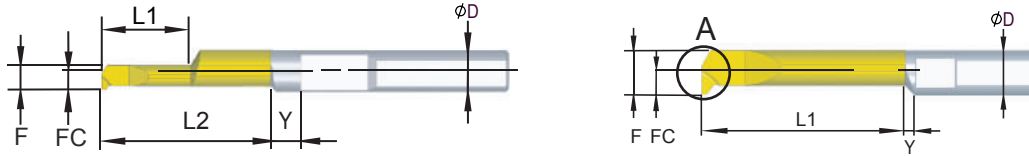

Item Number	D	Minimum Diameter	F	FC	R	W	H	Multiples	L1	L2	Y	Chipbreaker	Reference Plane (degree)	Coating Type
U318-3V1A3	3	2	1.8	1.4	0.05	0.3	0.5	3	6	6.78	4.22	✓	0	TiAlN
U318-4V1A3	3	2	1.8	1.4	0.05	0.3	0.5	4	8	9.9	3.5	✓	0	TiAlN
U318-5V1A3	3	2	1.8	1.4	0.05	0.3	0.5	5	10	14	2	✓	0	TiAlN
U318-6V1A3	3	2	1.8	1.4	0.05	0.3	0.5	6	12	12	4	✓	0	TiAlN
U318-7V1A3	3	2	1.8	1.4	0.05	0.3	0.5	7	14	17	3	✓	0	TiAlN
U329-3V1A3	3	3.2	2.9	1.4	0.05	0.4	0.7	3	9	-	2	✓	0	TiAlN
U329-4V1A3	3	3.2	2.9	1.4	0.05	0.4	0.7	4	11.4	-	2	✓	0	TiAlN
U329-5V1A3	3	3.2	2.9	1.4	0.05	0.4	0.7	5	14	-	2	✓	0	TiAlN
U329-6V1A3	3	3.2	2.9	1.4	0.05	0.4	0.7	6	18	-	2	✓	0	TiAlN
U329-7V1A3	3	3.2	2.9	1.4	0.05	0.4	0.7	7	21	-	2	✓	0	TiAlN
U439-3V1A3	4	4.2	3.9	1.9	0.1	0.5	0.8	3	11	-	2	✓	0	TiAlN
U439-4V1A3	4	4.2	3.9	1.9	0.1	0.5	0.8	4	14.5	-	2	✓	0	TiAlN
U439-5V1A3	4	4.2	3.9	1.9	0.1	0.5	0.8	5	18	-	2	✓	0	TiAlN
U439-6V1A3	4	4.2	3.9	1.9	0.1	0.5	0.8	6	23	-	2	✓	0	TiAlN
U439-7V1A3	4	4.2	3.9	1.9	0.1	0.5	0.8	7	27	-	2	✓	0	TiAlN
U549-3V1A3	5	5.2	4.9	2.4	0.1	0.5	1.1	3	15	-	2	✓	0	TiAlN
U549-4V1A3	5	5.2	4.9	2.4	0.1	0.5	1.1	4	19	-	2	✓	0	TiAlN
U549-5V1A3	5	5.2	4.9	2.4	0.1	0.5	1.1	5	23	-	2	✓	0	TiAlN
U549-6V1A3	5	5.2	4.9	2.4	0.1	0.5	1.1	6	30	-	2	✓	0	TiAlN
U549-7V1A3	5	5.2	4.9	2.4	0.1	0.5	1.1	7	35	-	2	✓	0	TiAlN
U659-3V1A3	6	6.2	5.9	2.9	0.1	0.5	1.2	3	17	-	2	✓	0	TiAlN
U659-4V1A3	6	6.2	5.9	2.9	0.1	0.5	1.2	4	23	-	2	✓	0	TiAlN
U659-5V1A3	6	6.2	5.9	2.9	0.1	0.5	1.2	5	28	-	2	✓	0	TiAlN
U659-6V1A3	6	6.2	5.9	2.9	0.1	0.5	1.2	6	34	-	2	✓	0	TiAlN
U659-7V1A3	6	6.2	5.9	2.9	0.1	0.5	1.2	7	42	-	2	✓	0	TiAlN

# UQ Tool

## 50 Degree Turning Tool (Radius Tip)

- ▶ **Specification** |  $\varnothing 1.0 - \varnothing 8.0$  mm, Japanese tungsten carbide.
- ▶ **Feature** | For roughing & finishing.
- ▶ **Coating** | Swiss coating equipment with European coating targets.

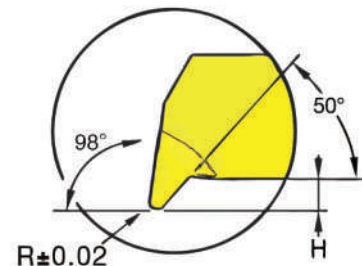
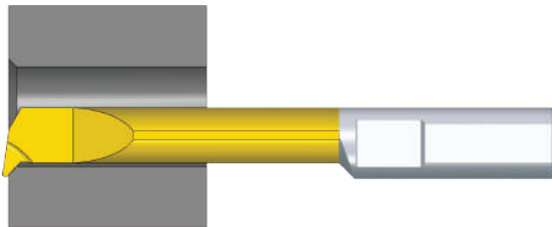

**Tool Numbering** : 3□☆○

- |  |   |                                    |                           |                             |                         |                          |                             |                               |                              |                             |                               |
|--|---|------------------------------------|---------------------------|-----------------------------|-------------------------|--------------------------|-----------------------------|-------------------------------|------------------------------|-----------------------------|-------------------------------|
| <p>3 : Multiples of F</p> <p>□ : Chipbreaker Type<br/>V=Breaker Groove<br/>P=Flat</p> <p>☆ : Reference Plane<br/>1=0°<br/>3=180°</p> | <p>○ : Coating Type</p> <table border="0"> <tr> <td><b>A3</b> = TiAlN (S-Fire) coating</td> <td><b>A1</b> = TiSiN coating</td> </tr> <tr> <td><b>A4</b> = AlTiCrN coating</td> <td><b>B9</b> = DLC coating</td> </tr> <tr> <td><b>A8</b> = ta-C coating</td> <td><b>BX</b> = AlTiSiN coating</td> </tr> <tr> <td><b>A9</b> = ZrAlTiSiN coating</td> <td><b>BX5</b> = AlCrSiN coating</td> </tr> <tr> <td><b>AS</b> = AlCrSiN coating</td> <td><b>BZ</b> = ZrAlTiSiN coating</td> </tr> </table> | <b>A3</b> = TiAlN (S-Fire) coating | <b>A1</b> = TiSiN coating | <b>A4</b> = AlTiCrN coating | <b>B9</b> = DLC coating | <b>A8</b> = ta-C coating | <b>BX</b> = AlTiSiN coating | <b>A9</b> = ZrAlTiSiN coating | <b>BX5</b> = AlCrSiN coating | <b>AS</b> = AlCrSiN coating | <b>BZ</b> = ZrAlTiSiN coating |
| <b>A3</b> = TiAlN (S-Fire) coating   | <b>A1</b> = TiSiN coating   |                                    |                           |                             |                         |                          |                             |                               |                              |                             |                               |
| <b>A4</b> = AlTiCrN coating  | <b>B9</b> = DLC coating   |                                    |                           |                             |                         |                          |                             |                               |                              |                             |                               |
| <b>A8</b> = ta-C coating   | <b>BX</b> = AlTiSiN coating   |                                    |                           |                             |                         |                          |                             |                               |                              |                             |                               |
| <b>A9</b> = ZrAlTiSiN coating  | <b>BX5</b> = AlCrSiN coating  |                                    |                           |                             |                         |                          |                             |                               |                              |                             |                               |
| <b>AS</b> = AlCrSiN coating  | <b>BZ</b> = ZrAlTiSiN coating   |                                    |                           |                             |                         |                          |                             |                               |                              |                             |                               |



**V** Breaker Groove



**Reference Plane 0°**



**P** Flat



**Reference Plane 180°**

### Remark

- Item numbers are based on 0° reference plane, V chip breaker, and TiAlN(S-Fire) coating.
- Please advise if 180° reference plane, flat type, uncoated, or TiSiN coating is required.
- Full customization available for all dimensions, including F / FC / L1 / L2 / W / H /  $\varnothing D$  / Tip radius / Front angle, in addition to the standard 50° front turning + back chamfering tool.
- Inch dimensions can be manufactured upon request.

## 50 Degree Turning Tool (Radius Tip)

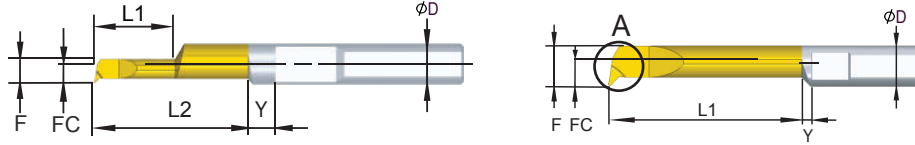

Item Number	D	Minimum Diameter	F	FC	R	H	Multiples	L1	L2	Y	Chipbreaker	Reference Plane (degree)	Coating Type
UQ318-3V1A3-R05	3	2	1.8	1.4	0.05	0.5	3	6	6.5	4.5	✓	0	TiAlN
UQ318-4V1A3-R05	3	2	1.8	1.4	0.05	0.5	4	8	10.4	3	✓	0	TiAlN
UQ318-5V1A3-R05	3	2	1.8	1.4	0.05	0.5	5	10	13	3	✓	0	TiAlN
UQ329-3V1A3-R10	3	3.2	2.9	1.4	0.1	0.7	3	9	-	2	✓	0	TiAlN
UQ329-4V1A3-R10	3	3.2	2.9	1.4	0.1	0.7	4	11.4	-	2	✓	0	TiAlN
UQ329-5V1A3-R10	3	3.2	2.9	1.4	0.1	0.7	5	14	-	2	✓	0	TiAlN
UQ329-6V1A3-R10	3	3.2	2.9	1.4	0.1	0.7	6	18	-	2	✓	0	TiAlN
UQ329-7V1A3-R10	3	3.2	2.9	1.4	0.1	0.7	7	21	-	2	✓	0	TiAlN
UQ439-3V1A3-R20	4	4.2	3.9	1.9	0.2	0.8	3	11	-	2	✓	0	TiAlN
UQ439-4V1A3-R20	4	4.2	3.9	1.9	0.2	0.8	4	14.5	-	2	✓	0	TiAlN
UQ439-5V1A3-R20	4	4.2	3.9	1.9	0.2	0.8	5	18	-	2	✓	0	TiAlN
UQ439-6V1A3-R20	4	4.2	3.9	1.9	0.2	0.8	6	23	-	2	✓	0	TiAlN
UQ439-7V1A3-R20	4	4.2	3.9	1.9	0.2	0.8	7	27	-	2	✓	0	TiAlN
UQ549-3V1A3-R20	5	5.2	4.9	2.4	0.2	1.1	3	15	-	2	✓	0	TiAlN
UQ549-4V1A3-R20	5	5.2	4.9	2.4	0.2	1.1	4	19	-	2	✓	0	TiAlN
UQ549-5V1A3-R20	5	5.2	4.9	2.4	0.2	1.1	5	23	-	2	✓	0	TiAlN
UQ549-6V1A3-R20	5	5.2	4.9	2.4	0.2	1.1	6	30	-	2	✓	0	TiAlN
UQ549-7V1A3-R20	5	5.2	4.9	2.4	0.2	1.1	7	35	-	2	✓	0	TiAlN
UQ659-3V1A3-R20	6	6.2	5.9	2.9	0.2	1.4	3	17	-	2	✓	0	TiAlN
UQ659-4V1A3-R20	6	6.2	5.9	2.9	0.2	1.4	4	23	-	2	✓	0	TiAlN
UQ659-5V1A3-R20	6	6.2	5.9	2.9	0.2	1.4	5	28	-	2	✓	0	TiAlN
UQ659-6V1A3-R20	6	6.2	5.9	2.9	0.2	1.4	6	34	-	2	✓	0	TiAlN
UQ659-7V1A3-R20	6	6.2	5.9	2.9	0.2	1.4	7	42	-	2	✓	0	TiAlN

# G Tool

## Grooving Tool

- ▶▶ **Specification** |  $\varnothing 1.0 - \varnothing 8.0$  mm, Japanese tungsten carbide.
- ▶▶ **Feature** | For roughing & finishing.
- ▶▶ **Coating** | Swiss coating equipment with European coating targets.

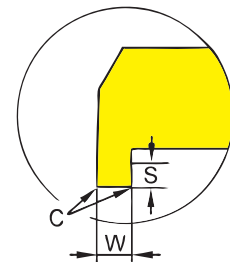
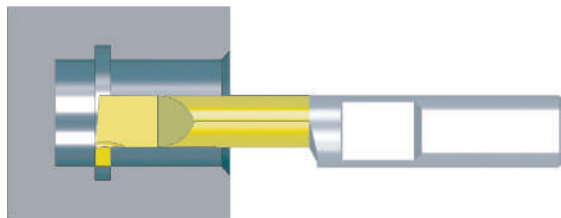

A (See Drawing)

**Tool Numbering** : 3 □ ☆ ○

- |   |  |
|---|--|
| <ul style="list-style-type: none"> <li>3 : Multiples of F</li> <li>□ : Chipbreaker Type<br/>V=Breaker Groove<br/>P=Flat</li> <li>☆ : Reference Plane<br/>1=0°<br/>3=180°</li> </ul> | <ul style="list-style-type: none"> <li>○ : Coating Type</li> <li>A3 = TiAlN (S-Fire) coating</li> <li>A4 = AlTiCrN coating</li> <li>A8 = ta-C coating</li> <li>A9 = ZrAlTiSiN coating</li> <li>AS = AlCrSiN coating</li> <li>A1 = TiSiN coating</li> <li>B9 = DLC coating</li> <li>BX = AlTiSiN coating</li> <li>BX5= AlCrSiN coating</li> <li>BZ = ZrAlTiSiN coating</li> </ul> |
|---|--|



V Breaker Groove



Reference Plane 0°



P Flat



Reference Plane 180°

### Remark

- Item numbers are based on 0° reference plane, V chip breaker, and TiAlN(S-Fire) coating.
- Please advise if 180° reference plane, flat type, uncoated, or TiSiN coating is required.
- Full customization available for all dimensions, including F / FC / L1 / L2 / W / S / C /  $\varnothing D$  / Tip radius / Front angle, in addition to the standard grooving tool.
- Inch dimensions can be manufactured upon request.

## Grooving Tool

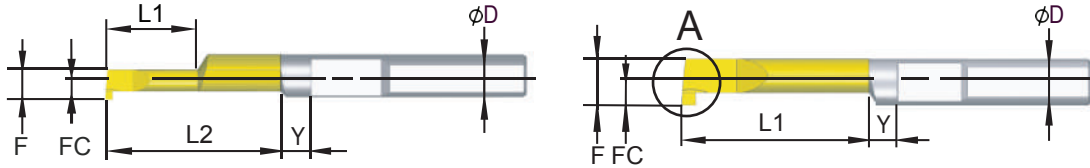

Item Number	D	Minimum Diameter	F	FC	W	S	H	Multiples	L1	Y	C±0.01	Chipbreaker	Reference Plane (degree)	Coating Type
G318-05035-3V1A3	3	2	1.8	1.4	0.5	0.35	0.5	3	9	2	0	✓	0	TiAlN
G318-05035-4V1A3	3	2	1.8	1.4	0.5	0.35	0.5	4	11.4	2	0	✓	0	TiAlN
G30505-3V1A3	3	3.2	2.9	1.4	0.5	0.5	0.7	3	9	2	0.04	✓	0	TiAlN
G30505-4V1A3	3	3.2	2.9	1.4	0.5	0.5	0.7	4	11.4	2	0.04	✓	0	TiAlN
G30505-5V1A3	3	3.2	2.9	1.4	0.5	0.5	0.7	5	14	2	0.04	✓	0	TiAlN
G307508-3V1A3	3	3.2	2.9	1.4	0.75	0.8	1	3	9	2	0.04	✓	0	TiAlN
G307508-4V1A3	3	3.2	2.9	1.4	0.75	0.8	1	4	11.4	2	0.04	✓	0	TiAlN
G307508-5V1A3	3	3.2	2.9	1.4	0.75	0.8	1	5	14	2	0.04	✓	0	TiAlN
G40505-3V1A3	4	4.2	3.9	1.9	0.5	0.5	0.7	3	11	2	0.04	✓	0	TiAlN
G40505-4V1A3	4	4.2	3.9	1.9	0.5	0.5	0.7	4	14.5	2	0.04	✓	0	TiAlN
G40505-5V1A3	4	4.2	3.9	1.9	0.5	0.5	0.7	5	18	2	0.04	✓	0	TiAlN
G407508-3V1A3	4	4.2	3.9	1.9	0.75	0.8	1	3	11	2	0.04	✓	0	TiAlN
G407508-4V1A3	4	4.2	3.9	1.9	0.75	0.8	1	4	14.5	2	0.04	✓	0	TiAlN
G407508-5V1A3	4	4.2	3.9	1.9	0.75	0.8	1	5	18	2	0.04	✓	0	TiAlN
G50506-3V1A3	5	5.2	4.9	2.4	0.5	0.6	0.8	3	15	2	0.04	✓	0	TiAlN
G50506-4V1A3	5	5.2	4.9	2.4	0.5	0.6	0.8	4	19	2	0.04	✓	0	TiAlN
G50506-5V1A3	5	5.2	4.9	2.4	0.5	0.6	0.8	5	23	2	0.04	✓	0	TiAlN
G51010-3V1A3	5	5.2	4.9	2.4	1	1	1.2	3	15	2	0.04	✓	0	TiAlN
G51010-4V1A3	5	5.2	4.9	2.4	1	1	1.2	4	19	2	0.04	✓	0	TiAlN
G51010-5V1A3	5	5.2	4.9	2.4	1	1	1.2	5	23	2	0.04	✓	0	TiAlN
G512515-3V1A3	5	5.2	4.9	2.4	1.25	1.5	1.7	3	15	2	0.04	✓	0	TiAlN
G512515-4V1A3	5	5.2	4.9	2.4	1.25	1.5	1.7	4	19	2	0.04	✓	0	TiAlN
G512515-5V1A3	5	5.2	4.9	2.4	1.25	1.5	1.7	5	23	2	0.04	✓	0	TiAlN
G60506-3V1A3	6	6.2	5.9	2.9	0.5	0.6	0.8	3	17	2	0.04	✓	0	TiAlN
G60506-4V1A3	6	6.2	5.9	2.9	0.5	0.6	0.8	4	23	2	0.04	✓	0	TiAlN
G60506-5V1A3	6	6.2	5.9	2.9	0.5	0.6	0.8	5	28	2	0.04	✓	0	TiAlN
G61015-3V1A3	6	6.2	5.9	2.9	1	1.5	1.7	3	17	2	0.04	✓	0	TiAlN
G61015-4V1A3	6	6.2	5.9	2.9	1	1.5	1.7	4	23	2	0.04	✓	0	TiAlN
G61015-5V1A3	6	6.2	5.9	2.9	1	1.5	1.7	5	28	2	0.04	✓	0	TiAlN
G61518-3V1A3	6	6.2	5.9	2.9	1.5	1.8	2	3	17	2	0.04	✓	0	TiAlN
G61518-4V1A3	6	6.2	5.9	2.9	1.5	1.8	2	4	23	2	0.04	✓	0	TiAlN
G61518-5V1A3	6	6.2	5.9	2.9	1.5	1.8	2	5	28	2	0.04	✓	0	TiAlN
G62022-3V1A3	6	6.2	5.9	2.9	2	2.2	2.4	3	17	2	0.04	✓	0	TiAlN
G62022-4V1A3	6	6.2	5.9	2.9	2	2.2	2.4	4	23	2	0.04	✓	0	TiAlN
G62022-5V1A3	6	6.2	5.9	2.9	2	2.2	2.4	5	28	2	0.04	✓	0	TiAlN

## Round Grooving Tool

- ▶▶ **Specification** |  $\varnothing 1.0 - \varnothing 8.0$  mm, Japanese tungsten carbide.
- ▶▶ **Feature** | For roughing & finishing.
- ▶▶ **Coating** | Swiss coating equipment with European coating targets.

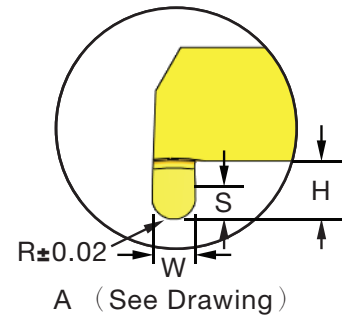
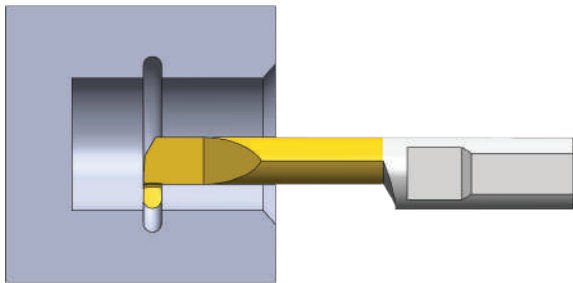

**Tool Numbering** : 3 □ ☆ ○

- |  |  |
|--|--|
| <p>3 : Multiples of F</p> <p>□ : Chipbreaker Type<br/>V=Breaker Groove<br/>P=Flat</p> <p>☆ : Reference Plane<br/>1=0°<br/>3=180°</p> | <p>○ : Coating Type</p> <p><b>A3</b> = TiAlN (S-Fire) coating<br/><b>A4</b> = AlTiCrN coating<br/><b>A8</b> = ta-C coating<br/><b>A9</b> = ZrAlTiSiN coating<br/><b>AS</b> = AlCrSiN coating</p> <p><b>A1</b> = TiSiN coating<br/><b>B9</b> = DLC coating<br/><b>BX</b> = AlTiSiN coating<br/><b>BX5</b> = AlCrSiN coating<br/><b>BZ</b> = ZrAlTiSiN coating</p> |
|--|--|



V Breaker Groove / Reference Plane 0°

### Remark

- Item numbers are based on 0° reference plane, V chip breaker, and TiAlN(S-Fire) coating.
- Please advise if 180° reference plane, flat type, uncoated, or TiSiN coating is required.
- Full customization available for all dimensions, including F / FC / L1 / L2 / W / S /  $\varnothing D$  / Tip radius / Front angle, in addition to the standard round grooving tool.
- Inch dimensions can be manufactured upon request.

## Round Grooving Tool

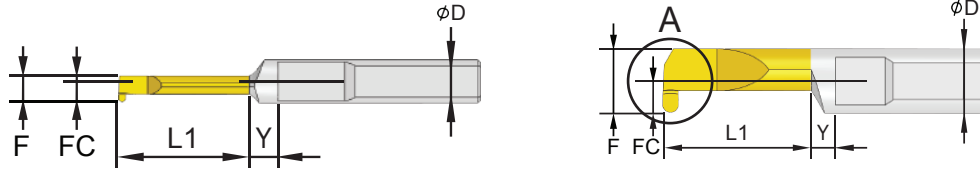

Item Number	D	Minimum Diameter	F	FC	W	S	H	Multiples	L1	Y	R	Chipbreaker	Reference Plane (degree)	Coating Type
GQ318-05035-3V1A3-R25	3	2	1.8	1.4	0.5	0.35	0.5	3	9	2	0.25	✓	0	TiAlN
GQ30607-3V1A3-R30	3	3.2	2.9	1.4	0.6	0.7	0.8	3	9	2	0.3	✓	0	TiAlN
GQ30607-5V1A3-R30	3	3.2	2.9	1.4	0.6	0.7	0.8	5	14	2	0.3	✓	0	TiAlN
GQ30808-3V1A3-R40	3	3.2	2.9	1.4	0.8	0.8	1	3	9	2	0.4	✓	0	TiAlN
GQ30808-5V1A3-R40	3	3.2	2.9	1.4	0.8	0.8	1	5	14	2	0.4	✓	0	TiAlN
GQ40505-3V1A3-R25	4	4.2	3.9	1.9	0.5	0.5	0.7	3	11	2	0.25	✓	0	TiAlN
GQ40505-5V1A3-R25	4	4.2	3.9	1.9	0.5	0.5	0.7	5	18	2	0.25	✓	0	TiAlN
GQ407508-3V1A3-R375	4	4.2	3.9	1.9	0.75	0.8	1	3	11	2	0.375	✓	0	TiAlN
GQ407508-5V1A3-R375	4	4.2	3.9	1.9	0.75	0.8	1	5	18	2	0.375	✓	0	TiAlN
GQ51010-3V1A3-R50	5	5.2	4.9	2.4	1	1	1.2	3	15	2	0.5	✓	0	TiAlN
GQ51010-5V1A3-R50	5	5.2	4.9	2.4	1	1	1.2	5	23	2	0.5	✓	0	TiAlN
GQ512515-3V1A3-R625	5	5.2	4.9	2.4	1.25	1.5	1.7	3	15	2	0.625	✓	0	TiAlN
GQ512515-5V1A3-R625	5	5.2	4.9	2.4	1.25	1.5	1.7	5	23	2	0.625	✓	0	TiAlN
GQ61015-3V1A3-R50	6	6.2	5.9	2.9	1	1.5	1.7	3	17	2	0.5	✓	0	TiAlN
GQ61015-5V1A3-R50	6	6.2	5.9	2.9	1	1.5	1.7	5	28	2	0.5	✓	0	TiAlN
GQ61518-3V1A3-R75	6	6.2	5.9	2.9	1.5	1.8	2	3	17	2	0.75	✓	0	TiAlN
GQ61518-5V1A3-R75	6	6.2	5.9	2.9	1.5	1.8	2	5	28	2	0.75	✓	0	TiAlN
GQ62022-3V1A3-R100	6	6.2	5.9	2.9	2	2.2	2.4	3	17	2	1	✓	0	TiAlN
GQ62022-5V1A3-R100	6	6.2	5.9	2.9	2	2.2	2.4	5	28	2	1	✓	0	TiAlN

# B Tool

## Back Turning Tool

- ▶▶ **Specification** |  $\varnothing 1.0 - \varnothing 8.0$  mm, Japanese tungsten carbide.
- ▶▶ **Feature** | For roughing & finishing.
- ▶▶ **Coating** | Swiss coating equipment with European coating targets.

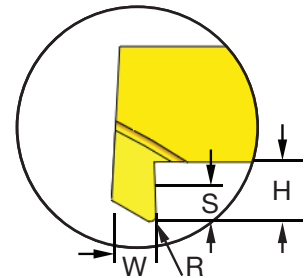
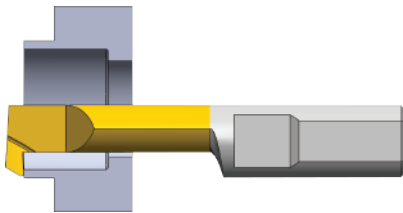

A (See Drawing)

**Tool Numbering** : 3□☆○

- |   |   |  |
|---|---|--|
| <ul style="list-style-type: none"> <li>3 : Multiples of F</li> <li>□ : Chipbreaker Type<br/>V=Breaker Groove<br/>P=Flat</li> <li>☆ : Reference Plane<br/>1=0°<br/>3=180°</li> </ul> | <ul style="list-style-type: none"> <li>○ : Coating Type</li> <li><b>A3</b> = TiAlN (S-Fire) coating</li> <li><b>A4</b> = AlTiCrN coating</li> <li><b>A8</b> = ta-C coating</li> <li><b>A9</b> = ZrAlTiSiN coating</li> <li><b>AS</b> = AlCrSiN coating</li> </ul> | <ul style="list-style-type: none"> <li><b>A1</b> = TiSiN coating</li> <li><b>B9</b> = DLC coating</li> <li><b>BX</b> = AlTiSiN coating</li> <li><b>BX5</b> = AlCrSiN coating</li> <li><b>BZ</b> = ZrAlTiSiN coating</li> </ul> |
|---|---|--|



V Breaker Groove / Reference Plane 0°

### Remark

- Item numbers are based on 0° reference plane, V chip breaker, and TiAlN(S-Fire) coating.
- Please advise if 180° reference plane, flat type, uncoated, or TiSiN coating is required.
- Full customization available for all dimensions, including F / FC / L1 / L2 / W / S /  $\varnothing D$  / Tip radius / Front angle, in addition to the standard back turning tool.
- Inch dimensions can be manufactured upon request.

# B Tool

## Back Turning Tool

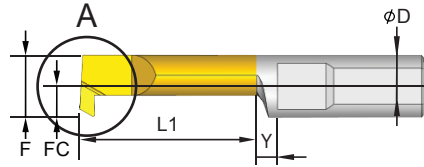

Item Number	D	Minimum Diameter	F	FC	W	S	H	Multiples	L1	Y	R	Chipbreaker	Reference Plane (degree)	Coating Type
B31505-3V1A3-R10	3	3.2	2.9	1.4	1.5	0.5	0.7	3	9	2	0.1	✓	0	TiAIN
B31505-5V1A3-R10	3	3.2	2.9	1.4	1.5	0.5	0.7	5	14	2	0.1	✓	0	TiAIN
B41508-3V1A3-R15	4	4.2	3.9	1.9	1.5	0.8	1	3	11	2	0.15	✓	0	TiAIN
B41508-5V1A3-R15	4	4.2	3.9	1.9	1.5	0.8	1	5	18	2	0.15	✓	0	TiAIN
B51510-3V1A3-R20	5	5.2	4.9	2.4	1.5	1	1.2	3	15	2	0.2	✓	0	TiAIN
B51510-5V1A3-R20	5	5.2	4.9	2.4	1.5	1	1.2	5	23	2	0.2	✓	0	TiAIN
B61518-3V1A3-R20	6	6.2	5.9	2.9	1.5	1.8	2	3	17	2	0.2	✓	0	TiAIN
B61518-5V1A3-R20	6	6.2	5.9	2.9	1.5	1.8	2	5	28	2	0.2	✓	0	TiAIN

# I Tool

## Threading Tool

▶ **Specification** |  $\varnothing 1.0 - \varnothing 8.0$  mm.

▶ **Feature** | For  $60^\circ / 55^\circ$  thread use.

▶ **Coating** | Swiss coating equipment with European coating targets.

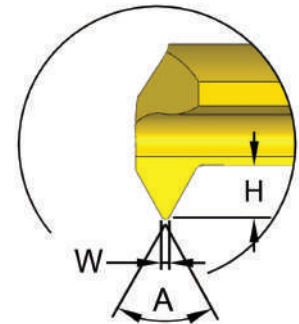
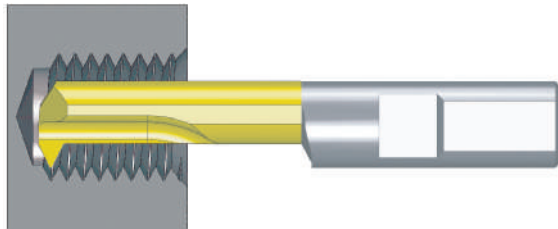

A (See Drawing)

**Tool Numbering** : 3□☆○

3 : Multiples of F

□ : Chipbreaker Type  
**V**=Breaker Groove  
**P**=Flat

☆ : Reference Plane  
**1**= $0^\circ$   
**3**= $180^\circ$

○ : Coating Type

**A3** = TiAlN (S-Fire) coating  
**A4** = AlTiCrN coating  
**A8** = ta-C coating  
**A9** = ZrAlTiSiN coating  
**AS** = AlCrSiN coating

**A1** = TiSiN coating  
**B9** = DLC coating  
**BX** = AlTiSiN coating  
**BX5** = AlCrSiN coating  
**BZ** = ZrAlTiSiN coating



**V** Breaker Groove



**Reference Plane**  $0^\circ$

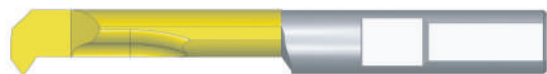

**P** Flat

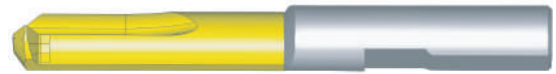

**Reference Plane**  $180^\circ$

### Remark

- Item numbers are based on  $0^\circ$  reference plane, V chip breaker, and TiAlN(S-Fire) coating.
- Please advise if  $180^\circ$  reference plane, flat type, uncoated, or TiSiN coating is required.
- Full customization available for all dimensions, including F / FC / L1 / L2 / W / H / A° /  $\varnothing$ D / Tip radius / Front angle, in addition to the standard threading tool.
- Inch dimensions can be manufactured upon request.

## Threading Tool

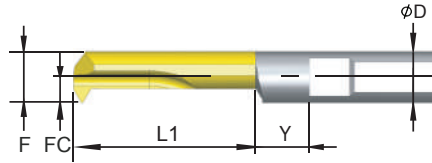

Item Number	D	F	FC	A	H	W	Maximum Pitch	Multiples	L1	Y	Chipbreaker	Reference Plane (degree)	Coating Type
i321-3V1A3	3	2.1	1.05	60	0.55	0.03	0.55	3	8	3	✓	0	TiAlN
i321-4V1A3	3	2.1	1.05	60	0.55	0.03	0.55	4	10.4	3	✓	0	TiAlN
i321-5V1A3	3	2.1	1.05	60	0.55	0.03	0.55	5	13	3	✓	0	TiAlN
i326-3V1A3	3	2.6	1.4	60	0.7	0.04	0.7	3	9	2	✓	0	TiAlN
i326-4V1A3	3	2.6	1.4	60	0.7	0.04	0.7	4	10.9	2.5	✓	0	TiAlN
i326-5V1A3	3	2.6	1.4	60	0.7	0.04	0.7	5	13	3	✓	0	TiAlN
i435-3V1A3	4	3.5	1.9	60	0.8	0.05	0.8	3	10	3	✓	0	TiAlN
i435-4V1A3	4	3.5	1.9	60	0.8	0.05	0.8	4	12.5	4	✓	0	TiAlN
i435-5V1A3	4	3.5	1.9	60	0.8	0.05	0.8	5	15	5	✓	0	TiAlN
i545-3V1A3	5	4.5	2.4	60	1.2	0.07	1.2	3	15	2	✓	0	TiAlN
i545-4V1A3	5	4.5	2.4	60	1.2	0.07	1.2	4	16	5	✓	0	TiAlN
i545-5V1A3	5	4.5	2.4	60	1.2	0.07	1.2	5	18	7	✓	0	TiAlN
i659-3V1A3	6	5.9	2.9	60	1.4	0.11	1.4	3	17	2	✓	0	TiAlN
i659-4V1A3	6	5.9	2.9	60	1.4	0.11	1.4	4	19	6	✓	0	TiAlN
i659-5V1A3	6	5.9	2.9	60	1.4	0.11	1.4	5	22	8	✓	0	TiAlN
i879-3V1A3	8	7.9	3.9	60	2	0.135	2	3	21	3	✓	0	TiAlN
i879-4V1A3	8	7.9	3.9	60	2	0.135	2	4	26	6	✓	0	TiAlN
i879-5V1A3	8	7.9	3.9	60	2	0.135	2	5	32	8	✓	0	TiAlN

Item Number	D	F	FC	A	H	W	Maximum Pitch	Multiples	L1	Y	Chipbreaker	Reference Plane (degree)	Coating Type
i321-3V1A3-55A	3	2.1	1.05	55	0.55	0.03	0.55	3	8	3	✓	0	TiAlN
i321-5V1A3-55A	3	2.1	1.05	55	0.55	0.03	0.55	5	13	3	✓	0	TiAlN
i326-3V1A3-55A	3	2.6	1.4	55	0.7	0.04	0.7	3	9	2	✓	0	TiAlN
i326-5V1A3-55A	3	2.6	1.4	55	0.7	0.04	0.7	5	13	3	✓	0	TiAlN
i435-3V1A3-55A	4	3.5	1.9	55	0.8	0.05	0.8	3	10	3	✓	0	TiAlN
i435-5V1A3-55A	4	3.5	1.9	55	0.8	0.05	0.8	5	15	5	✓	0	TiAlN
i545-3V1A3-55A	5	4.5	2.4	55	1.2	0.07	1.2	3	15	2	✓	0	TiAlN
i545-5V1A3-55A	5	4.5	2.4	55	1.2	0.07	1.2	5	18	7	✓	0	TiAlN
i659-3V1A3-55A	6	5.9	2.9	55	1.4	0.14	1.4	3	17	2	✓	0	TiAlN
i659-5V1A3-55A	6	5.9	2.9	55	1.4	0.14	1.4	5	22	8	✓	0	TiAlN

# D Tool

## Face Grooving Tool

- ▶▶ **Specification** |  $\varnothing 0.2 - \varnothing 8.0$  mm, Japanese tungsten carbide.
- ▶▶ **Feature** | Designed for machined workpiece apertures larger than  $\varnothing 6$ .  
| Suitable for difficult-to-cut materials, applicable for both roughing and finishing.
- ▶▶ **Coating** | Swiss coating equipment with European coating targets.

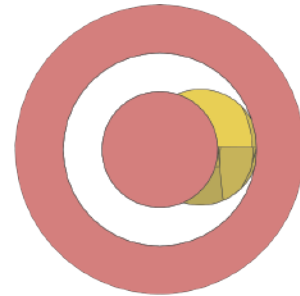
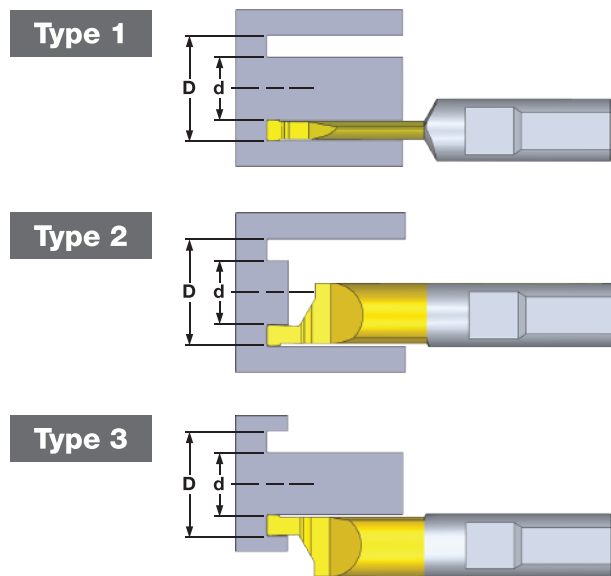

- ▶▶ Front view showcasing that the tool is designed to not interfere during the machining process of the workpiece.

### Tool Numbering : 3 □ ☆ ○

- |   |   |  |
|---|---|--|
| <ul style="list-style-type: none"> <li>3 : Multiples of F</li> <li>□ : Chipbreaker Type<br/>V=Breaker Groove<br/>P=Flat</li> <li>☆ : Reference Plane<br/>1=0°<br/>3=180°</li> </ul> | <ul style="list-style-type: none"> <li>○ : Coating Type</li> <li><b>A3</b> = TiAlN (S-Fire) coating</li> <li><b>A4</b> = AlTiCrN coating</li> <li><b>A8</b> = ta-C coating</li> <li><b>A9</b> = ZrAlTiSiN coating</li> <li><b>AS</b> = AlCrSiN coating</li> </ul> | <ul style="list-style-type: none"> <li><b>A1</b> = TiSiN coating</li> <li><b>B9</b> = DLC coating</li> <li><b>BX</b> = AlTiSiN coating</li> <li><b>BX5</b> = AlCrSiN coating</li> <li><b>BZ</b> = ZrAlTiSiN coating</li> </ul> |
|---|---|--|

### Remark

- Item numbers are based on 0° reference plane, V chip breaker, and TiAlN(S-Fire) coating.
- Please advise if 180° reference plane, flat type, uncoated, or TiSiN coating is required.
- Full customization available for all dimensions, including FC / L1 / L2 / W /  $\varnothing D$  / Tip radius, in addition to the standard face grooving tool.
- Inch dimensions can be manufactured upon request.

# D Tool

## Face Grooving Tool

**Type 1**

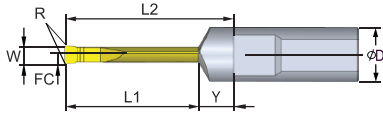

**Type 2**

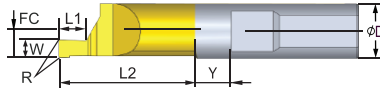

**Type 3**

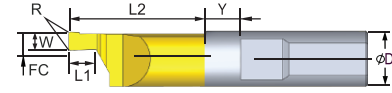

Type	Item Number	D	Minimum Diameter	FC	W	R	L1	L2	Y	Chipbreaker	Reference Plane (degree)	Coating Type	
Type 1	D605V-R03-L1.6-1A35	6	7.0	0.25	0.5	0.03	1.6	10	8.4	✓	0	TiAlN	
Type 1	D610V-R10-L4-1A35	6	8.0	0.5	1.0	0.1	4	10	6	✓	0	TiAlN	
Type 1	D615V-R15-L6-1A35	6	9.0	0.75	1.5	0.15	6	12	6	✓	0	TiAlN	
Type 1	D620V-R15-L8-1A35	6	10.0	1.0	2.0	0.15	8	15	7	✓	0	TiAlN	
<b>NEW</b>	Type 1	D625V-R15-L10-1A35	6	11.0	1.25	2.5	0.15	10	15	7	✓	0	TiAlN
<b>NEW</b>	Type 1	D630V-R15-L12-1A35	6	12.0	1.50	3.0	0.15	12	15	7	✓	0	TiAlN
Type 2	D605RV-R03-L1.2-1A35	6	7.0	2.9	0.5	0.03	1.2	15	4	✓	0	TiAlN	
Type 2	D610RV-R10-L1.5-1A35	6	8.0	2.9	1.0	0.1	1.5	15	4	✓	0	TiAlN	
Type 2	D615RV-R15-L2.5-1A35	6	9.0	2.9	1.5	0.15	2.5	15	4	✓	0	TiAlN	
Type 2	D620RV-R15-L3-1A35	6	10.0	2.9	2.0	0.15	3	15	4	✓	0	TiAlN	
<b>NEW</b>	Type 2	D625RV-R15-L5-1A35	6	11.0	2.9	2.5	0.15	5	15	4	✓	0	TiAlN
<b>NEW</b>	Type 2	D630RV-R15-L6-1A35	6	12.0	2.9	3.0	0.15	6	15	4	✓	0	TiAlN
Type 3	D605LV-R03-L1.2-1A35	6	7.0	2.9	0.5	0.03	1.2	15	4	✓	0	TiAlN	
Type 3	D610LV-R10-L1.5-1A35	6	8.0	2.9	1.0	0.1	1.5	15	4	✓	0	TiAlN	
Type 3	D615LV-R15-L2.5-1A35	6	9.0	2.9	1.5	0.15	2.5	15	4	✓	0	TiAlN	
Type 3	D620LV-R15-L3-1A35	6	10.0	2.9	2.0	0.15	3	15	4	✓	0	TiAlN	
<b>NEW</b>	Type 3	D625LV-R15-L5-1A35	6	11.0	2.9	2.5	0.15	5	15	4	✓	0	TiAlN
<b>NEW</b>	Type 3	D630LV-R15-L6-1A35	6	12.0	2.9	3.0	0.15	6	15	4	✓	0	TiAlN

## Round Face Grooving Tool

- ▶▶ **Specification** |  $\varnothing 0.2 - \varnothing 8.0$  mm, Japanese tungsten carbide.
- ▶▶ **Feature** | Designed for machined workpiece apertures larger than  $\varnothing 6$ .  
| Suitable for difficult-to-cut materials, applicable for both roughing and finishing.
- ▶▶ **Coating** | Swiss coating equipment with European coating targets.

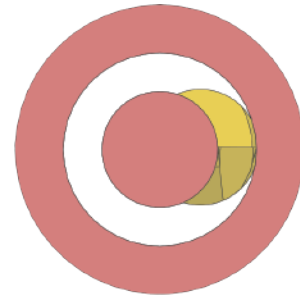
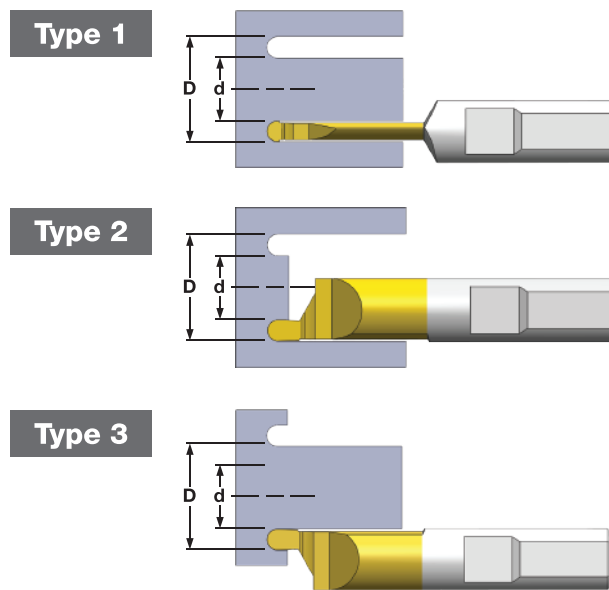

- ▶▶ Front view showcasing that the tool is designed to not interfere during the machining process of the workpiece.

### Tool Numbering : 3 □ ☆ ○

- |   |                    |            |                          |
|---|--------------------|------------|--------------------------|
| 3 | : Multiples of F   | ○          | : Coating Type           |
| □ | : Chipbreaker Type | <b>A3</b>  | = TiAlN (S-Fire) coating |
| V | = Breaker Groove   | <b>A4</b>  | = AlTiCrN coating        |
| P | = Flat             | <b>A8</b>  | = ta-C coating           |
| ☆ | : Reference Plane  | <b>A9</b>  | = ZrAlTiSiN coating      |
| 1 | = 0°               | <b>AS</b>  | = AlCrSiN coating        |
| 3 | = 180°             | <b>A1</b>  | = TiSiN coating          |
|   |                    | <b>B9</b>  | = DLC coating            |
|   |                    | <b>BX</b>  | = AlTiSiN coating        |
|   |                    | <b>BX5</b> | = AlCrSiN coating        |
|   |                    | <b>BZ</b>  | = ZrAlTiSiN coating      |

### Remark

- Item numbers are based on 0° reference plane, V chip breaker, and TiAlN(S-Fire) coating.
- Please advise if 180° reference plane, flat type, uncoated, or TiSiN coating is required.
- Full customization available for all dimensions, including FC / L1 / L2 / W /  $\varnothing D$  / Tip radius, in addition to the standard round face grooving tool.
- Inch dimensions can be manufactured upon request.

## Round Face Grooving Tool

**Type 1**

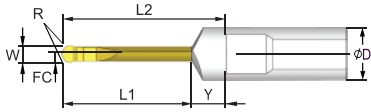

**Type 2**

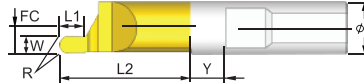

**Type 3**

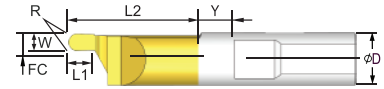

Type	Item Number	D	Minimum Diameter	FC	W	R	L1	L2	Y	Chipbreaker	Reference Plane (degree)	Coating Type
Type 1	DQ605V-R25-L1.6-1A35	6	7.0	0.25	0.5	0.25	1.6	10	8.4	✓	0	TiAlN
Type 1	DQ610V-R50-L4-1A35	6	8.0	0.5	1.0	0.5	4	10	6	✓	0	TiAlN
Type 1	DQ615V-R75-L6-1A35	6	9.0	0.75	1.5	0.75	6	12	6	✓	0	TiAlN
Type 1	DQ620V-R100-L8-1A35	6	10.0	1.0	2.0	1.0	8	15	7	✓	0	TiAlN
Type 2	DQ605RV-R25-L1.2-1A35	6	7.0	2.9	0.5	0.25	1.2	15	4	✓	0	TiAlN
Type 2	DQ610RV-R50-L1.5-1A35	6	8.0	2.9	1.0	0.5	1.5	15	4	✓	0	TiAlN
Type 2	DQ615RV-R75-L2.5-1A35	6	9.0	2.9	1.5	0.75	2.5	15	4	✓	0	TiAlN
Type 2	DQ620RV-R100-L3-1A35	6	10.0	2.9	2.0	1.0	3	15	4	✓	0	TiAlN
Type 3	DQ605LV-R25-L1.2-1A35	6	7.0	2.9	0.5	0.25	1.2	15	4	✓	0	TiAlN
Type 3	DQ610LV-R50-L1.5-1A35	6	8.0	2.9	1.0	0.5	1.5	15	4	✓	0	TiAlN
Type 3	DQ615LV-R75-L2.5-1A35	6	9.0	2.9	1.5	0.75	2.5	15	4	✓	0	TiAlN
Type 3	DQ620LV-R100-L3-1A35	6	10.0	2.9	2.0	1.0	3	15	4	✓	0	TiAlN

# D Tool

## Face Grooving Tool (Customized)

- ▶ **Specification** |  $\varnothing 0.2\text{mm} - \varnothing 8\text{mm}$ .
- ▶ **Tool Range** | Tungsten carbide materials are imported from Europe and Japan.
- ▶ **Feature** | General and heavy-duty type.
- ▶ **Remark** | We provide over 3000 type of customized face grooving tools and over 95% success cases.

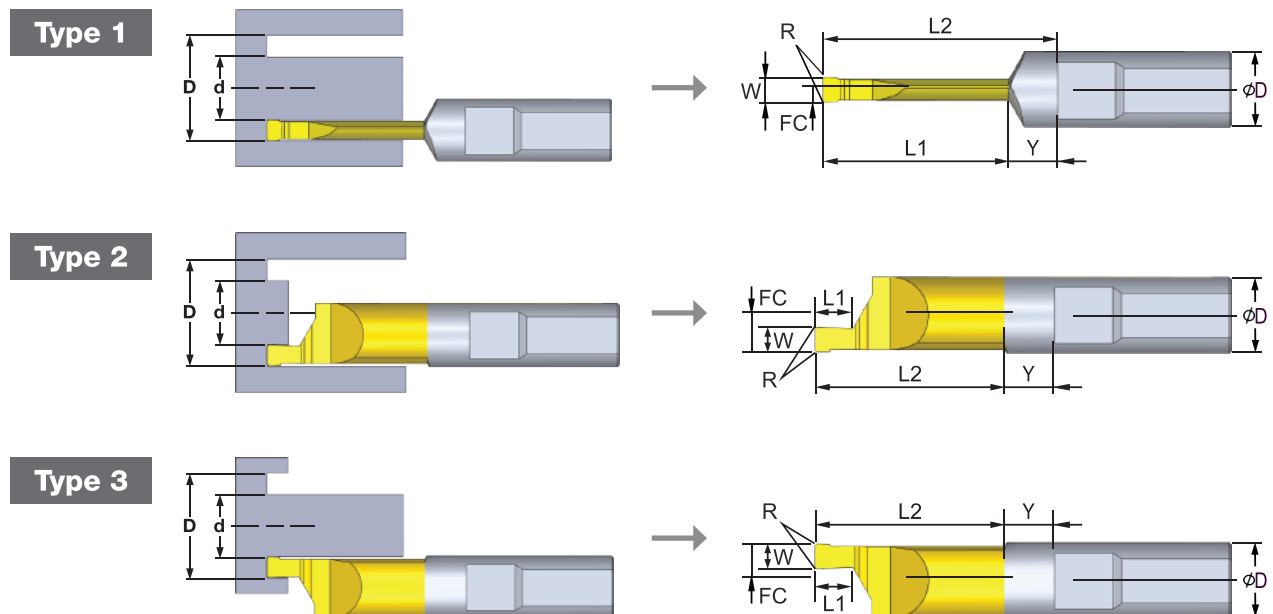
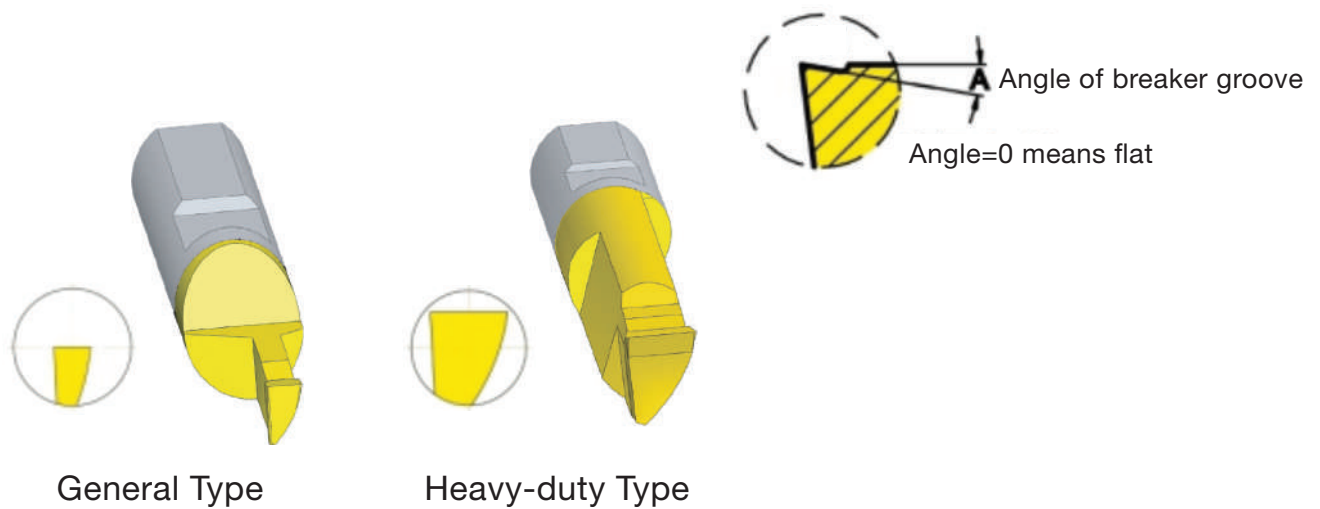

- ▶ We do customize face grooving tool with the above tool every dimensions including  $FC / L1 / L2 / W / \varnothing D /$  Tip Radius, according to your requirement.

## Face Grooving Tool (Customized)

### Videos Introduction

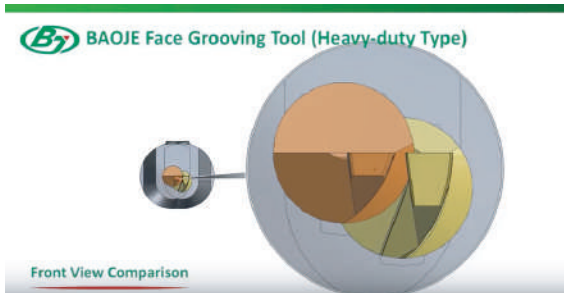

Revealing the Design of BAOJE Face Grooving Tool (Heavy-duty Type)

◀ View Full Video on YouTube



Innovative Applications of Special Face Grooving Tool

◀ View Full Video on YouTube

### Cases



# H Tool (T)

## Through Coolant - T Tool

- ▶▶ **Overview** | Tungsten carbide tool featuring a central coolant-through design for improved cooling performance and efficient chip removal.
- ▶▶ **Feature** | Effectively overcomes blind-hole machining challenges and reduces chip adhesion issues.
- ▶▶ **Coating** | Swiss coating equipment with European coating targets.

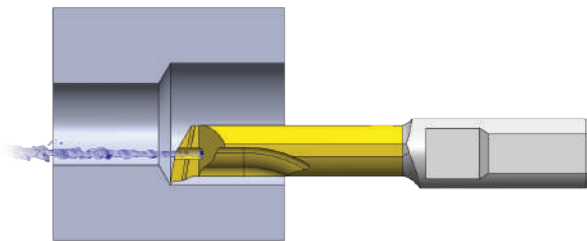

V Breaker Groove / Reference Plane 0°

**Tool Numbering** : 3 □ ☆ ○

- |  |   |                                    |                           |                             |                         |                          |                             |                               |                              |                             |                               |
|--|---|------------------------------------|---------------------------|-----------------------------|-------------------------|--------------------------|-----------------------------|-------------------------------|------------------------------|-----------------------------|-------------------------------|
| <p>3 : Multiples of F</p> <p>□ : Chipbreaker Type<br/>V=Breaker Groove<br/>P=Flat</p> <p>☆ : Reference Plane<br/>1=0°<br/>3=180°</p> | <p>○ : Coating Type</p> <table border="0"> <tr> <td><b>A3</b> = TiAlN (S-Fire) coating</td> <td><b>A1</b> = TiSiN coating</td> </tr> <tr> <td><b>A4</b> = AlTiCrN coating</td> <td><b>B9</b> = DLC coating</td> </tr> <tr> <td><b>A8</b> = ta-C coating</td> <td><b>BX</b> = AlTiSiN coating</td> </tr> <tr> <td><b>A9</b> = ZrAlTiSiN coating</td> <td><b>BX5</b> = AlCrSiN coating</td> </tr> <tr> <td><b>AS</b> = AlCrSiN coating</td> <td><b>BZ</b> = ZrAlTiSiN coating</td> </tr> </table> | <b>A3</b> = TiAlN (S-Fire) coating | <b>A1</b> = TiSiN coating | <b>A4</b> = AlTiCrN coating | <b>B9</b> = DLC coating | <b>A8</b> = ta-C coating | <b>BX</b> = AlTiSiN coating | <b>A9</b> = ZrAlTiSiN coating | <b>BX5</b> = AlCrSiN coating | <b>AS</b> = AlCrSiN coating | <b>BZ</b> = ZrAlTiSiN coating |
| <b>A3</b> = TiAlN (S-Fire) coating   | <b>A1</b> = TiSiN coating   |                                    |                           |                             |                         |                          |                             |                               |                              |                             |                               |
| <b>A4</b> = AlTiCrN coating  | <b>B9</b> = DLC coating   |                                    |                           |                             |                         |                          |                             |                               |                              |                             |                               |
| <b>A8</b> = ta-C coating   | <b>BX</b> = AlTiSiN coating   |                                    |                           |                             |                         |                          |                             |                               |                              |                             |                               |
| <b>A9</b> = ZrAlTiSiN coating  | <b>BX5</b> = AlCrSiN coating  |                                    |                           |                             |                         |                          |                             |                               |                              |                             |                               |
| <b>AS</b> = AlCrSiN coating  | <b>BZ</b> = ZrAlTiSiN coating   |                                    |                           |                             |                         |                          |                             |                               |                              |                             |                               |

### Remark

- Item numbers are based on 0° reference plane, V chip breaker, and TiAlN(S-Fire) coating.
- Please advise if 180° reference plane, flat type, uncoated, or TiSiN coating is required.
- Full customization available for all dimensions, including F / FC / L1 / L2 / ØD / Tip radius / Front angle, in addition to the standard 10° turning tool.
- Inch dimensions can be manufactured upon request.

# H Tool (T)

## Through Coolant - T Tool

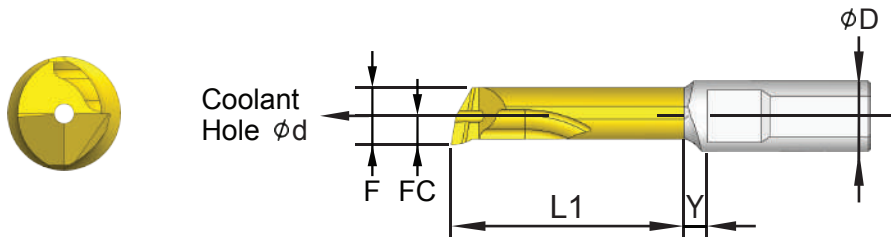

Item Number	D	Minimum Diameter	F	FC	R	Multiples	L1	L2	Y	Coolant Hole	Chipbreaker	Reference Plane (degree)	Coating Type
T418-6LV1BX-R05-5H	4	2	1.8	0.9	0.05	3	6	7	4	0.5	✓	0	AITiSiN
T418-10LV1BX-R05-5H	4	2	1.8	0.9	0.05	5	10	12	4	0.5	✓	0	AITiSiN
T429-3V1BX-5H	4	3.2	2.9	1.45	0.1	3	11	-	2	0.5	✓	0	AITiSiN
T429-5V1BX-5H	4	3.2	2.9	1.45	0.1	5	18	-	2	0.5	✓	0	AITiSiN
T439-3V1BX-5H	4	4.2	3.9	1.9	0.1	3	11	-	2	0.5	✓	0	AITiSiN
T439-5V1BX-5H	4	4.2	3.9	1.9	0.1	5	18	-	2	0.5	✓	0	AITiSiN
T649-3V1BX-5H	6	5.2	4.9	2.45	0.1	3	17	-	2	1	✓	0	AITiSiN
T649-5V1BX-5H	6	5.2	4.9	2.45	0.1	5	28	-	2	1	✓	0	AITiSiN
T659-3V1BX-5H	6	6.2	5.9	2.9	0.1	3	17	-	2	1	✓	0	AITiSiN
T659-5V1BX-5H	6	6.2	5.9	2.9	0.1	5	28	-	2	1	✓	0	AITiSiN

# H Tool (UQ)

## Through Coolant - UQ Tool

- ▶ **Overview** | Tungsten carbide tool featuring a central coolant-through design for improved cooling performance and efficient chip removal.
- ▶ **Feature** | Effectively overcomes blind-hole machining challenges and reduces chip adhesion issues.
- ▶ **Coating** | Swiss coating equipment with European coating targets.

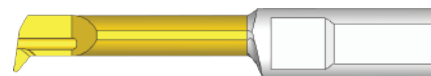
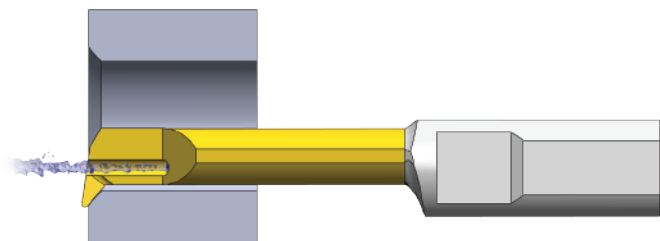

V Breaker Groove / Reference Plane 0°

**Tool Numbering** : 3□☆○

- |   |                    |           |                          |            |                     |
|---|--------------------|-----------|--------------------------|------------|---------------------|
| 3 | : Multiples of F   | ○         | : Coating Type           |            |                     |
| □ | : Chipbreaker Type | <b>A3</b> | = TiAlN (S-Fire) coating | <b>A1</b>  | = TiSiN coating     |
| V | = Breaker Groove   | <b>A4</b> | = AlTiCrN coating        | <b>B9</b>  | = DLC coating       |
| P | = Flat             | <b>A8</b> | = ta-C coating           | <b>BX</b>  | = AlTiSiN coating   |
| ☆ | : Reference Plane  | <b>A9</b> | = ZrAlTiSiN coating      | <b>BX5</b> | = AlCrSiN coating   |
| 1 | = 0°               | <b>AS</b> | = AlCrSiN coating        | <b>BZ</b>  | = ZrAlTiSiN coating |
| 3 | = 180°             |           |                          |            |                     |

### Remark

- Item numbers are based on 0° reference plane, V chip breaker, and TiAlN(S-Fire) coating.
- Please advise if 180° reference plane, flat type, uncoated, or TiSiN coating is required.
- Full customization available for all dimensions, including F / FC / L1 / L2 / W / H / ØD / Tip radius / Front angle, in addition to the standard 50° front turning + back chamfering tool.
- Inch dimensions can be manufactured upon request.

# H Tool (UQ)

## Through Coolant - UQ Tool

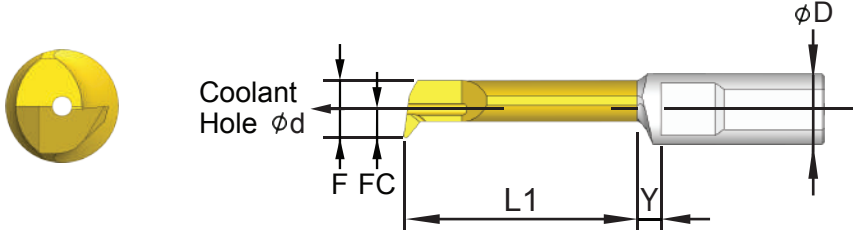

Item Number	D	Minimum Diameter	F	FC	R	Multiples	L1	L2	Y	Coolant Hole	Chipbreaker	Reference Plane (degree)	Coating Type
UQ429-3V1BX-R20-5H	4	3.2	2.9	1.45	0.2	3	11	-	2	0.5	✓	0	AITiSiN
UQ429-5V1BX-R20-5H	4	3.2	2.9	1.45	0.2	5	18	-	2	0.5	✓	0	AITiSiN
UQ439-3V1BX-R20-5H	4	4.2	3.9	1.9	0.2	3	11	-	2	0.5	✓	0	AITiSiN
UQ439-5V1BX-R20-5H	4	4.2	3.9	1.9	0.2	5	18	-	2	0.5	✓	0	AITiSiN
UQ649-3V1BX-R20-5H	6	5.2	4.9	2.45	0.2	3	17	-	2	1	✓	0	AITiSiN
UQ649-5V1BX-R20-5H	6	5.2	4.9	2.45	0.2	5	28	-	2	1	✓	0	AITiSiN
UQ659-3V1BX-R20-5H	6	6.2	5.9	2.9	0.2	3	17	-	2	1	✓	0	AITiSiN
UQ659-5V1BX-R20-5H	6	6.2	5.9	2.9	0.2	5	28	-	2	1	✓	0	AITiSiN

## Double Cutting Edge (TT/UU/UQUQ)

### Double Cutting Edge Series

TT 10 Degree Turning Tool

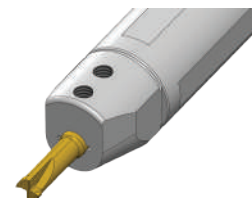
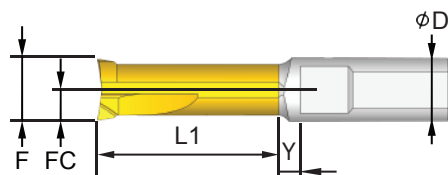

UU 50 Degree Turning Tool

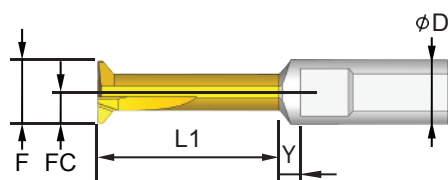

UQUQ 50 Degree Turning Tool (Radius Tip)

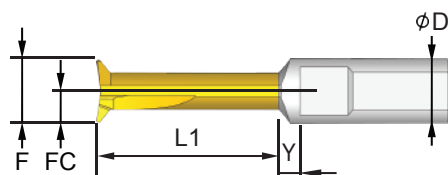

### Feature

1. The world's first double edge internal boring tool with foolproof design, mirroring the economic model of double-edged inserts on the market.
2. Paired with a special tool holder for foolproof attachment.
3. ESG application reduces tungsten carbide consumption.

### Usage

1. Recommended for holes larger than  $\Phi 10\text{mm}$ .
2. Best used with high-pressure oil equipment.

Combining these methods prevents chip entanglement and tool edge damage.

### Compatible with special reference tool holder models.

BJA-1905-06-95WBY

BJA-20-06-100WBY

BJA-22-06-110WBY

BJA-25-06-90WBY

BJA-254-06-90WBY

(Y=Special Reference Plane)

### Tool Numbering : 3U1○

3 : Multiples of F

○ : Coating Type

U=Chip Groove

A3 = TiAlN (S-Fire) coating

A4 = AlTiCrN coating

A8 = ta-C coating

A9 = ZrAlTiSiN coating

AS = AlCrSiN coating

A1 = TiSiN coating

B9 = DLC coating

BX = AlTiSiN coating

BX5= AlCrSiN coating

BZ = ZrAlTiSiN coating

## Double Cutting Edge (TT/UU/UQUQ)

Item Number	D	Minimum Diameter	F	FC	R	Multiples	L1	L2	Y	DC Type	Chipbreaker	Reference Plane (degree)	Coating Type
TT658-3U1BX	6	10	5.8	2.9	0.1	3	17	-	2	TT	✓	Y	AITISIN
TT658-3U1BX-R20	6	10	5.8	2.9	0.2	3	17	-	2	TT	✓	Y	AITISIN
UU658-3U1BX	6	10	5.8	2.9	0.1	3	17	-	2	UU	✓	Y	AITISIN
UQUQ658-3U1BX	6	10	5.8	2.9	0.2	3	17	-	2	UQUQ	✓	Y	AITISIN

### ▶▶ Model 1. Roughing + Finishing Cutting Edge

A boring tool that combines a roughing and a finishing cutting edge, allowing both functions to be achieved efficiently with a single tool, optimizing performance and reducing tool changes.

Finishing Cutting Edge

Roughing Cutting Edge

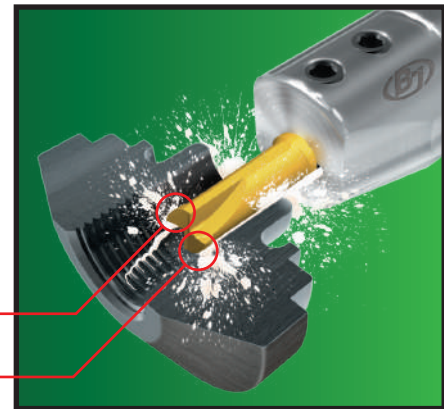

### ▶▶ Model 2. Same Edge for Double Lifespan

A boring tool with two cutting edges that serve the same function. When one edge becomes dull, the other can be used, effectively doubling the tool's lifespan without the need for replacement.

Same Cutting Function. Simply Rotate the Tool to Use the Other Edge When One Dulls.

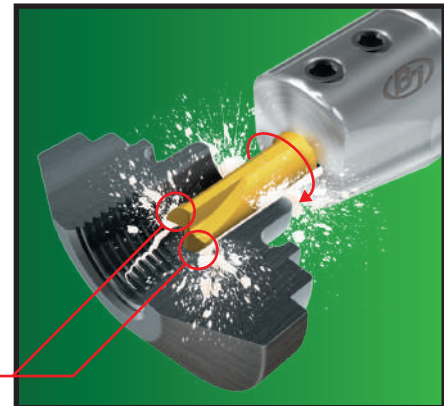

### ▶▶ Model 3. Custom Edge Combination

A boring tool with two cutting edges that can be customized to your specifications. Choose from turning, grooving, and threading edges to achieve two distinct functions with one tool.

Edge 1: Turning / Grooving / Threading

Edge 2: Turning / Grooving / Threading

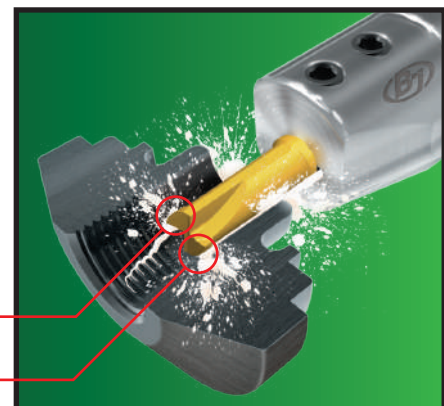

# DH Tool

## Double Head Cutting Edge (TT) NEW

The world's first dual-head, twin-edge innovation with foolproof locking design.

### ▶▶ Rising Tungsten Carbide Costs? We Help You Save.

With global rare-earth supply restrictions driving up tungsten carbide prices, BJ DH Tools are designed to reduce overall tooling costs—creating a true win-win solution.

### ▶▶ Feature

1. The world's first dual-head, twin-edge innovation with a foolproof locking design, eliminating installation errors and delivering a safety advantage beyond standard competitor solutions.
2. Economical - save more, spend less on operating costs.
3. Compatible with BJ Standard Toolholders—just replace the ball plunger screw.
4. BJ boring bar has a special center V groove design. When used with a ball plunger screw, it securely fixes the tool overhang length.

### ▶▶ Tool Clamping Procedure



- ① Loosen both the front ball plunger screw and the rear set screw.
- ② Insert approximately one-third of the tool length into the holder, **then lightly tighten the front ball plunger screw.**
- ③ Push the tool further until half of its length is inserted; the ball plunger screw will engage with the center groove.
- ④ Lightly tighten the ball plunger screw, then firmly tighten the rear set screw. The recommended tightening torque is 2.0Nm.

### Precautions for Use

- Insert the tool carefully to avoid damaging the secondary cutting edge. Protective adhesive is applied to both ends.
- Always loosen the clamping screw before tool replacement.

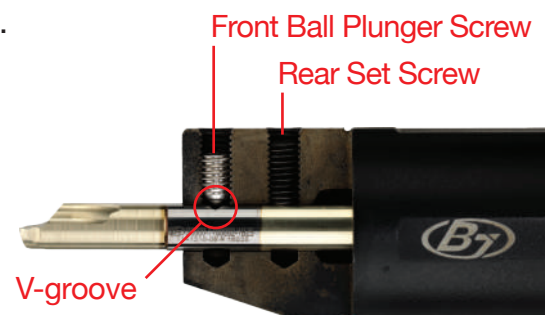

## Double Head Cutting Edge (TT) NEW

Item Number	D	Minimum Diameter	F	FC	R	Multiples	L1	L2	L	DC Type	Chipbreaker	Reference Plane (degree)	Coating Type
DHTT657-24LV1A3-5	6	6	5.7	2.7	0.1	4	24	24	60	TT	✓	Y	TiAlN
DHTT657-24LV1A3-R20-5	6	6	5.7	2.7	0.2	4	24	24	60	TT	✓	Y	TiAlN

### ▶▶ Model 1. Fixed 4V Tool Overhang

(the front ball plunger screw engaged in the central V-groove of the tool)

The tool is clamped with a fixed 4V overhang length following the standard Tool Clamping Procedure. Each time the cutting edge is replaced, repeatability is approximately  $\pm 0.05$  mm, ensuring dimensional accuracy and faster machine operation.



### ▶▶ Model 2. Shortened 4V Tool Overhang

To shorten the tool overhang, loosen the front ball plunger screw, adjust the tool to the desired shorter overhang length, and tighten the rear set screw to secure.

**Warning: Do NOT tighten the front ball plunger screw. Tightening may cause damage.**



### ▶▶ Model 3. Extended 4V Tool Overhang

To extend the tool overhang, loosen the front ball plunger screw, adjust the tool to the desired longer overhang length, and tighten the rear set screw to secure.

**Warning: Do NOT tighten the front ball plunger screw. Tightening may cause damage.**



# Holders Classification

## Holders Classification

D Type



Direct Toolholders ————— BJA

B Type



Butterfly Toolholders ———— { BJMA (STAR)  
 BJJ (STAR)  
 BJR (STAR)  
 BJN (NOMURA)

F Type

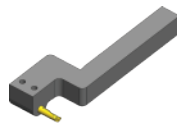

Flash Toolholders ————— BJZN-E

H Type

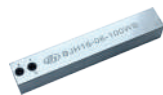

Square Shank Toolholders ——— BJH

S Type



Special Toolholders ——— Customized  
 upon request



# D Type Toolholder Series

## Direct Toolholder (D Type)

### ► Specification :

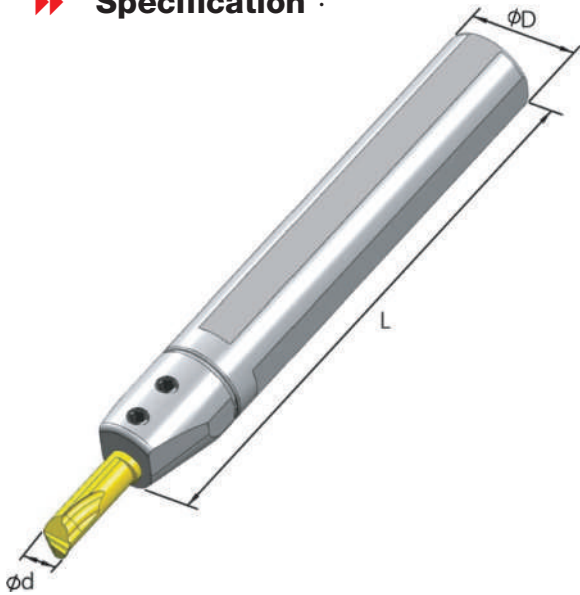

Item Number	Specification		
	ØD	Ød	L
BJA-12-03-70WB	12	3	70
BJA-12-04-70WB	12	4	70
BJA-12-05-70WB	12	5	70
BJA-12-06-70W	12	6	70
BJA-16-03-100WB	16	3	100
BJA-16-04-100WB	16	4	100
BJA-16-05-100WB	16	5	100
BJA-16-06-100WB	16	6	100
BJA-17-03-100WB	17	3	100
BJA-17-04-100WB	17	4	100
BJA-17-05-100WB	17	5	100
BJA-17-06-100WB	17	6	100
BJA-1905-03-70WB	19.05	3	70
BJA-1905-04-70WB	19.05	4	70
BJA-1905-05-70WB	19.05	5	70
BJA-1905-06-70WB	19.05	6	70
BJA-1905-08-70WB	19.05	8	70
BJA-1905-03-95WB	19.05	3	95
BJA-1905-04-95WB	19.05	4	95
BJA-1905-05-95WB	19.05	5	95
BJA-1905-06-95WB	19.05	6	95
BJA-1905-08-95WB	19.05	8	95
BJA-1905-03-125WB	19.05	3	125
BJA-1905-04-125WB	19.05	4	125
BJA-1905-05-125WB	19.05	5	125
BJA-1905-06-125WB	19.05	6	125
BJA-1905-08-125WB	19.05	8	125

Quick Change Tool for first-timer and customized upon your request.



# D Type Toolholder Series

## Direct Toolholder (D Type)

### ►► Specification :

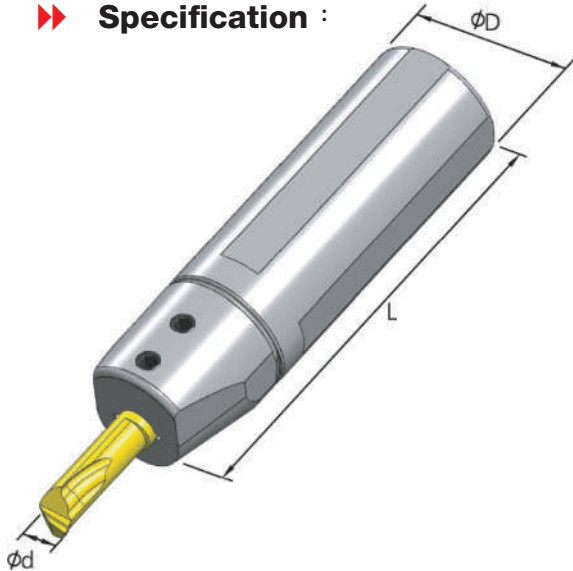

Item Number	Specification		
	ØD	Ød	L
BJA-20-03-70WB	20	3	70
BJA-20-04-70WB	20	4	70
BJA-20-05-70WB	20	5	70
BJA-20-06-70WB	20	6	70
BJA-20-08-70WB	20	8	70
BJA-20-03-100WB	20	3	100
BJA-20-04-100WB	20	4	100
BJA-20-05-100WB	20	5	100
BJA-20-06-100WB	20	6	100
BJA-20-08-100WB	20	8	100
BJA-20-03-150WB	20	3	150
BJA-20-04-150WB	20	4	150
BJA-20-05-150WB	20	5	150
BJA-20-06-150WB	20	6	150
BJA-20-08-150WB	20	8	150

### ►► Specification :

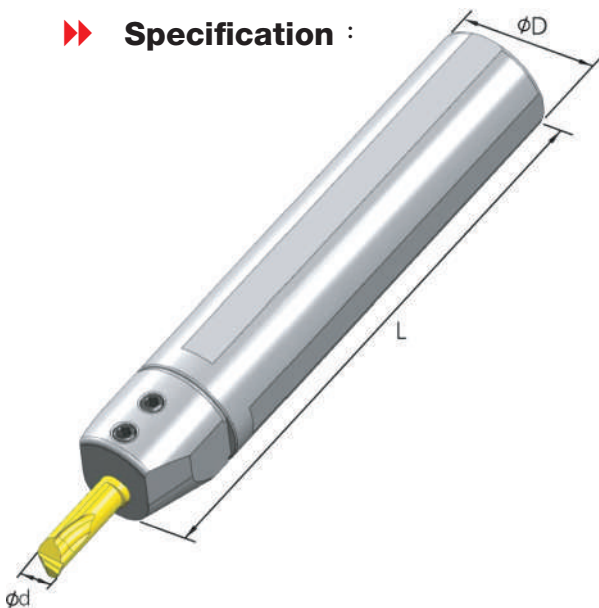

Item Number	Specification		
	ØD	Ød	L
BJA-22-03-110WB	22	3	110
BJA-22-04-110WB	22	4	110
BJA-22-05-110WB	22	5	110
BJA-22-06-110WB	22	6	110
BJA-22-08-110WB	22	8	110
BJA-22-03-150WB	22	3	150
BJA-22-04-150WB	22	4	150
BJA-22-05-150WB	22	5	150
BJA-22-06-150WB	22	6	150
BJA-22-08-150WB	22	8	150

Quick Change Tool for first-timer and customized upon your request.

# D Type Toolholder Series

## Direct Toolholder (D Type)

### ►► Specification :

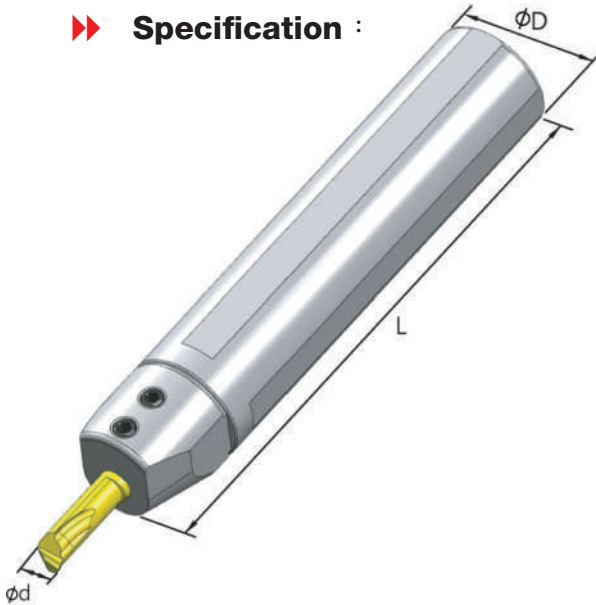

Item Number	Specification		
	ØD	Ød	L
BJA-23-03-110WB	23	3	110
BJA-23-04-110WB	23	4	110
BJA-23-05-110WB	23	5	110
BJA-23-06-110WB	23	6	110
BJA-23-08-110WB	23	8	110

### ►► Specification :

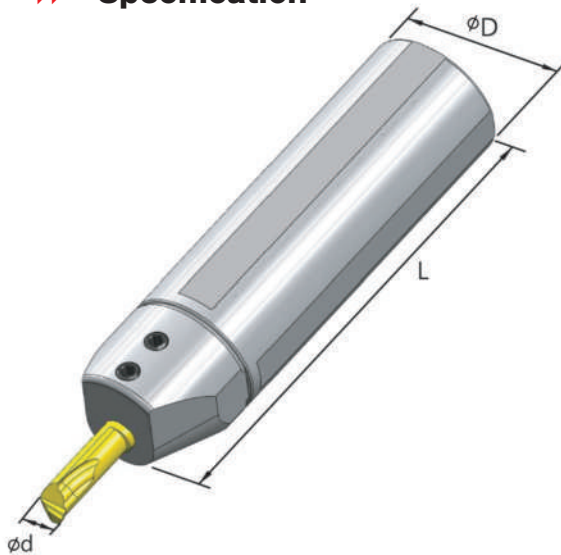

Item Number	Specification		
	ØD	Ød	L
BJA-25-03-90WB	25	3	90
BJA-25-04-90WB	25	4	90
BJA-25-05-90WB	25	5	90
BJA-25-06-90WB	25	6	90
BJA-25-08-90WB	25	8	90
BJA-25-03-150WB	25	3	150
BJA-25-04-150WB	25	4	150
BJA-25-05-150WB	25	5	150
BJA-25-06-150WB	25	6	150
BJA-25-08-150WB	25	8	150
BJA-254-03-90WB	25.4	3	90
BJA-254-04-90WB	25.4	4	90
BJA-254-05-90WB	25.4	5	90
BJA-254-06-90WB	25.4	6	90
BJA-254-08-90WB	25.4	8	90
BJA-254-03-150WB	25.4	3	150
BJA-254-04-150WB	25.4	4	150
BJA-254-05-150WB	25.4	5	150
BJA-254-06-150WB	25.4	6	150
BJA-254-08-150WB	25.4	8	150

Quick Change Tool for first-timer and customized upon your request.

# B Type Toolholder Series

## Butterfly Toolholder (B Type)

### ►► Specification :

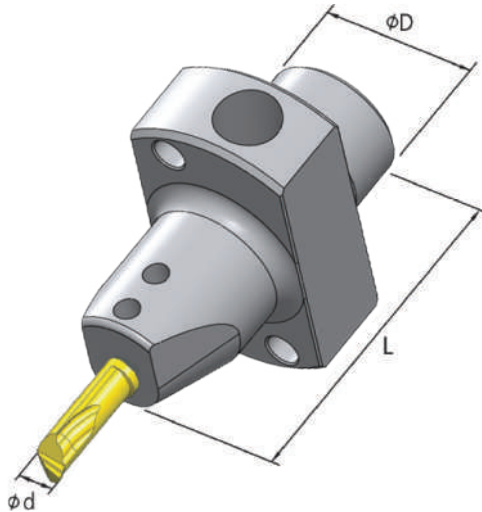

Item Number	Specification			Type of Machine
	ØD	Ød	L	
BJMA-22-03-59WB	22	3	59	STAR
BJMA-22-04-59WB	22	4	59	STAR
BJMA-22-05-59WB	22	5	59	STAR
BJMA-22-06-59WB	22	6	59	STAR
BJMA-22-08-59WB	22	8	59	STAR

### ►► Specification :

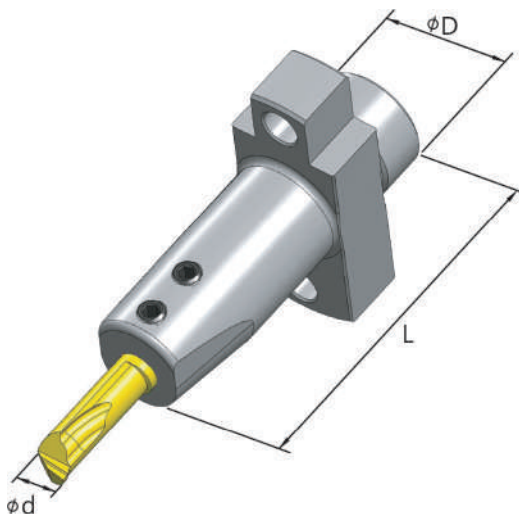

Item Number	Specification			Type of Machine
	ØD	Ød	L	
BJJ-16-03-53WB	16	3	53	STAR 10J
BJJ-16-04-53WB	16	4	53	STAR 10J
BJJ-16-05-53WB	16	5	53	STAR 10J
BJJ-16-06-53WB	16	6	53	STAR 10J

Quick Change Tool for first-timer and customized upon your request.

# B Type Toolholder Series

## Butterfly Toolholder (B Type)

### ►► Specification :

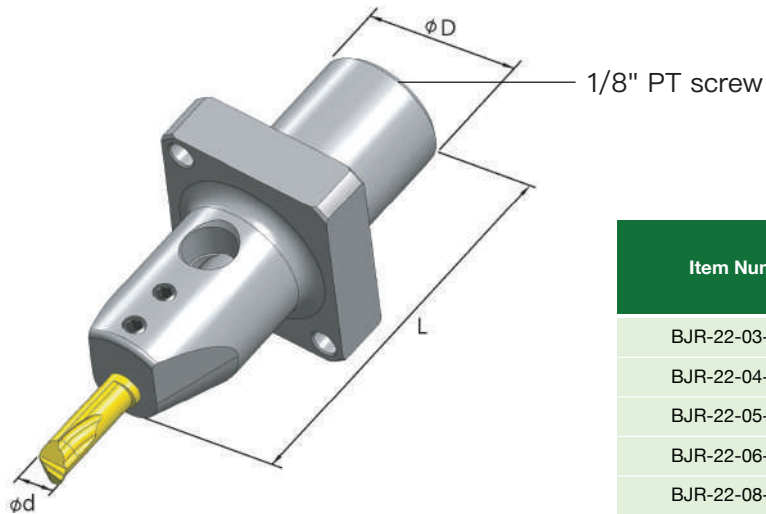

Item Number	Specification			Type of Machine
	ØD	Ød	L	
BJR-22-03-69WB	22	3	69	STAR 20RIV
BJR-22-04-69WB	22	4	69	STAR 20RIV
BJR-22-05-69WB	22	5	69	STAR 20RIV
BJR-22-06-69WB	22	6	69	STAR 20RIV
BJR-22-08-69WB	22	8	69	STAR 20RIV

### ►► Specification :

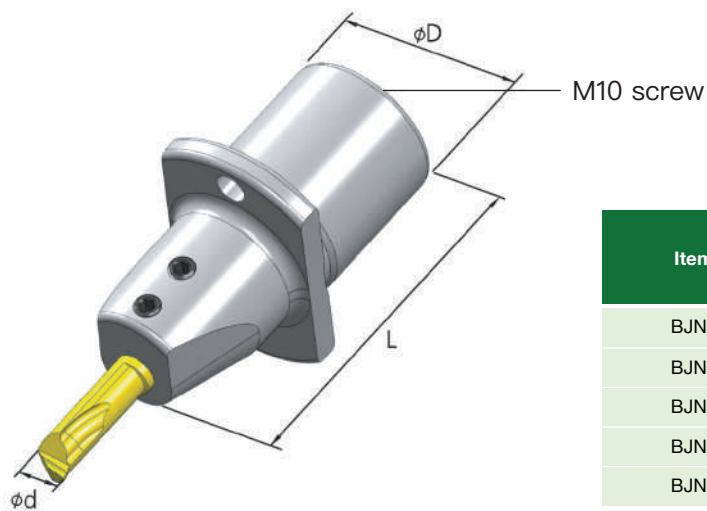

Item Number	Specification			Type of Machine
	ØD	Ød	L	
BJN-23-03-53	23	3	53	NOMURA
BJN-23-04-53	23	4	53	NOMURA
BJN-23-05-53	23	5	53	NOMURA
BJN-23-06-53	23	6	53	NOMURA
BJN-23-08-53	23	8	53	NOMURA

Quick Change Tool for first-timer and customized upon your request.

# B Type Toolholder Series

## Butterfly Toolholder (B Type)

### ►► Specification :

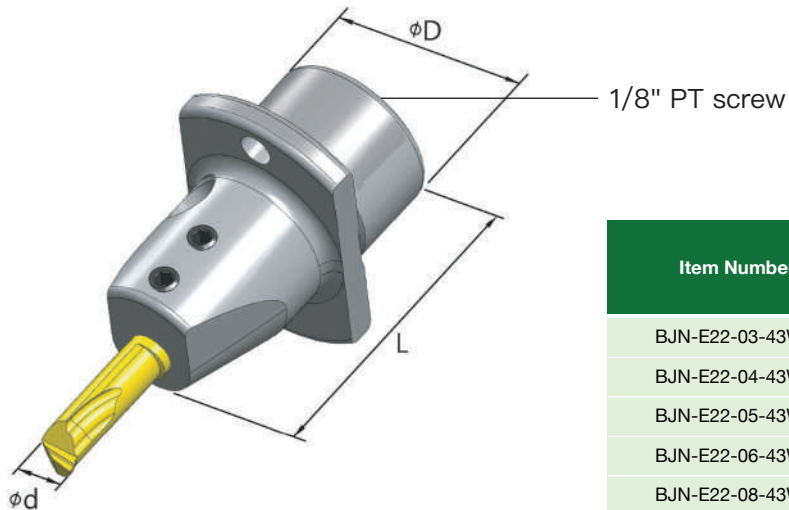

Item Number	Specification			Type of Machine
	ØD	Ød	L	
BJN-E22-03-43WB	22	3	43	NOMURA
BJN-E22-04-43WB	22	4	43	NOMURA
BJN-E22-05-43WB	22	5	43	NOMURA
BJN-E22-06-43WB	22	6	43	NOMURA
BJN-E22-08-43WB	22	8	43	NOMURA

### ►► Specification :

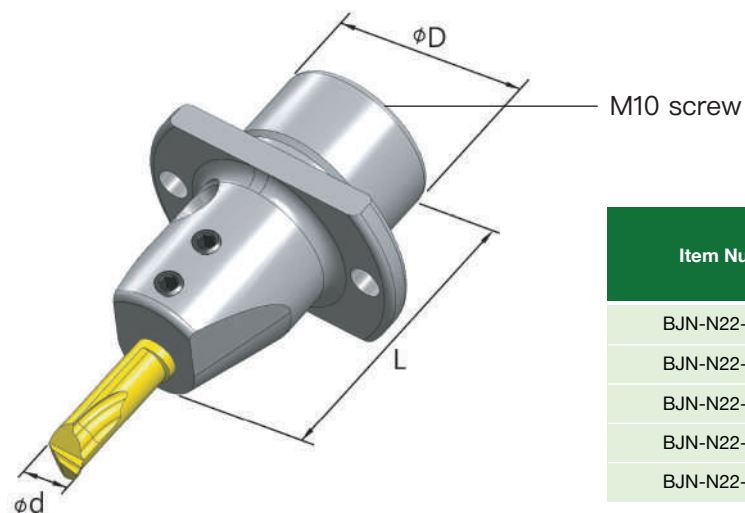

Item Number	Specification			Type of Machine
	ØD	Ød	L	
BJN-N22-03-43B	22	3	43	NOMURA
BJN-N22-04-43B	22	4	43	NOMURA
BJN-N22-05-43B	22	5	43	NOMURA
BJN-N22-06-43B	22	6	43	NOMURA
BJN-N22-08-43B	22	8	43	NOMURA

Quick Change Tool for first-timer and customized upon your request.

# F Type Toolholder Series

## Flash Toolholder (F Type)

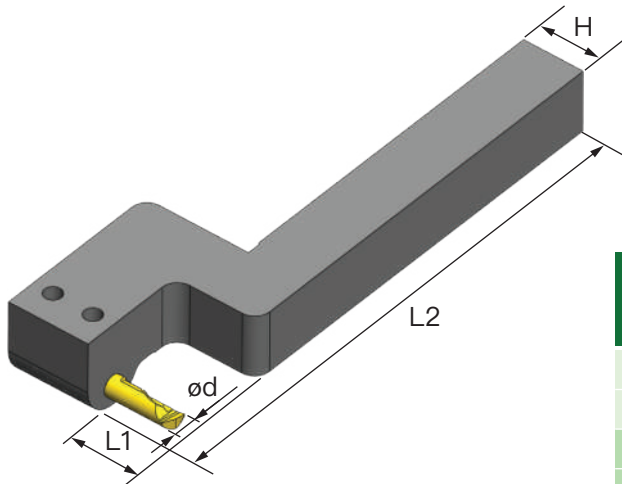

Item Number	Specification			
	H	Ød	L1	L2
BJZN-E10-03-4	10	3	13.4	100
BJZN-E10-04-4	10	4	16.5	100
BJZN-E12-03-4	12	3	13.4	100
BJZN-E12-04-4	12	4	16.5	100
BJZN-E12-05-4	12	5	21	100
BJZN-E12-06-3	12	6	19	100
BJZN-E12-06-4	12	6	21	100



Quick Change Tool for first-timer and customized upon your request.

# H Type Toolholder Series

## ■ Square Shank Toolholders (H Type)

### ▶▶ Specification :

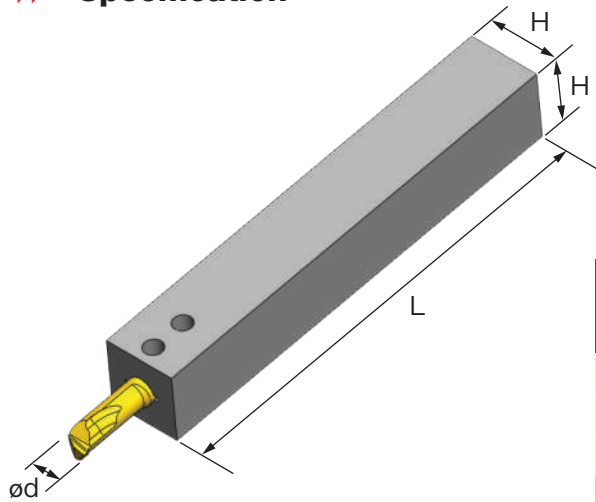

Item Number	Specification		
	H	Ød	L
BJH-10-03-70WB	10	3	70
BJH-10-04-70WB	10	4	70
BJH-10-05-70WB	10	5	70
BJH-12-03-100WB	12	3	100
BJH-12-04-100WB	12	4	100
BJH-12-05-100WB	12	5	100
BJH-12-06-100W	12	6	100
BJH-14-03-100WB	14	3	100
BJH-14-04-100WB	14	4	100
BJH-14-05-100WB	14	5	100
BJH-14-06-100WB	14	6	100
BJH-16-03-100WB	16	3	100
BJH-16-04-100WB	16	4	100
BJH-16-05-100WB	16	5	100
BJH-16-06-100WB	16	6	100
BJH-20-03-100WB	20	3	100
BJH-20-04-100WB	20	4	100
BJH-20-05-100WB	20	5	100
BJH-20-06-100WB	20	6	100
BJH-20-08-100WB	20	8	100

Quick Change Tool for first-timer and customized upon your request.

# S Type Toolholder Series

## Special Toolholder (S Type)

### ►► Specification :

Based on your machine type, we can design customized holders to meet your demand.



This is a holder designed for use in multi-axis lathe machine. ►

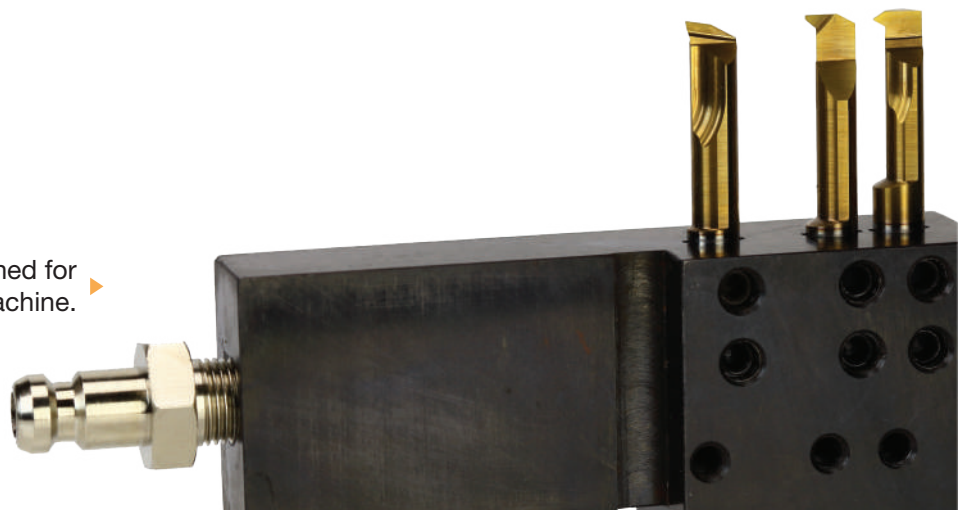

Quick Change Tool for first-timer and customized upon your request.

# BJ Torque Screwdriver Kits

## Introduction: BJ Torque Screwdriver

---

In order to standardize the cutting tool tightening, Baoje systematic cutting tools introduce a torque screwdriver to tighten the cutting tool. For Baoje cutting tool shank different diameters of Ø3, Ø4, Ø5, Ø6, Ø8, different torque screwdrivers are used to tighten the cutting tool. There is a cue sound feature, when the preset torque is reached, a Click sound will be made, which can prevent the operator from using excessive force to break the cutting tool and increase the stability of the cutting tool tightening.

Baoje torque screwdriver is assembled with three parts. First part is the screwdriver handle, which is suitable for various torque applications; the second part is the preset torque adapter. We made different preset torque adapters according to different Baoje cutting tool shank diameters of Ø3, Ø4, Ø5, Ø6, Ø8. And there are color management and important lasered information on the adapter to prevent operator making mistakes; Third part is the screwdriver bit. The screw specifications on the Baoje toolholder are mainly M4 and M5. The required screwdriver bit specifications are H2.0 and H2.5. In addition, we also provide TX8, TX9, TX10, TX15. These screwdriver bit allows customers to tighten the CNC inserts. These three parts can be replaced flexibly, which is very convenient and safe for the operator.

## BJ Torque Screwdriver Features

---



Quick and Flexible  
Interchangeable



Reversible  
Loosen System



Click Sound



Cutting Tool Tightening  
Standardization

# BJ Torque Screwdriver Kits

## ■ Introduction: BJ Torque Screwdriver Kit

Baoje systematic cutting tool made five kits for preset torque adapter and bits according to different Baoje cutting tool shank diameters of Ø3, Ø4, Ø5, Ø6, and Ø8 for customers to choose. Torque screwdriver is assembled with three parts.

### ▶▶ First Part

First part is the screwdriver handle, which is suitable for various torque applications.

### ▶▶ Second Part

The second part is the preset torque adapter. We made different preset torque adapters according to different Baoje cutting tool shank diameters of Ø3, Ø4, Ø5, Ø6, Ø8. Torque adapter has a cue sound feature, when the preset torque is reached will make a click sound continuously. And there are color management and important lasered information on the adapter to prevent operator making mistakes.

### ▶▶ Third Part

Third part is the screwdriver bit. The screw specifications on the Baoje toolholder are mainly M4 and M5. The required screwdriver bit specifications are H2.0 and H2.5. In addition, we also provide TX8, TX9, TX10, TX15. These screwdriver bit allows customers to tighten the CNC inserts. These three parts can be replaced flexibly, which is very convenient and safe for the operator, special attention should be paid to when assembling the bit, it is necessary to assemble the corresponding torque adapter, because the smaller specification bit cannot withstand the heavier torque adapter, will easy damage the bit and may cause the bit to fall off.



# BJ Torque Screwdriver Kits

## BJ Torque Screwdriver Kit

### BJ-TSD-NO-3

Handle	<b>BJ-TRF * 1 pc</b>
Adapter	<b>BJ-ADA-NO-3 * 1 pc</b>
Bit H2.0	<b>1 pc</b>
H2.5	<b>2 pcs</b>
TX	<b>TX8 * 2 pcs</b>



### BJ-TSD-NO-4

Handle	<b>BJ-TRF * 1 pc</b>
Adapter	<b>BJ-ADA-NO-4 * 1 pc</b>
Bit H2.0	<b>1 pc</b>
H2.5	<b>2 pcs</b>
TX	<b>TX9 * 2 pcs</b>



### BJ-TSD-NO-5

Handle	<b>BJ-TRF * 1 pc</b>
Adapter	<b>BJ-ADA-NO-5 * 1 pc</b>
Bit H2.0	<b>1 pc</b>
H2.5	<b>2 pcs</b>
TX	<b>TX10 * 2 pcs</b>



### BJ-TSD-NO-6

Handle	<b>BJ-TRF * 1 pc</b>
Adapter	<b>BJ-ADA-NO-6 * 1 pc</b>
Bit H2.0	<b>0</b>
H2.5	<b>3 pcs</b>
TX	<b>TX15 * 2 pcs</b>



# BJ Torque Screwdriver Kits

## BJ-TSD-NO-8

Handle	<b>BJ-TRF * 1 pc</b>
Adapter	<b>BJ-ADA-NO-8 * 1 pc</b>
Bit H2.0	<b>0</b>
H2.5	<b>3 pcs</b>
TX	<b>TX15 * 2 pcs</b>



## BJ Torque Screwdriver Handle

▶▶ Handle item number: BJ-TRF

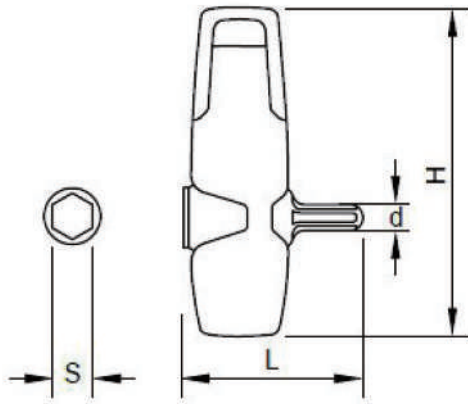

Item No.	Color	S	L	H	d	N.W.
BJ-TRF	Red	6.35	70.7	37.5	5	25g

# BJ Torque Screwdriver Kits

## Adapter of Torque Screwdriver Characteristic



Reversible  
Loosening System



Torque Adapter  
Can Tighten  
About 20,000 Times



Torque Adapter  
Torque Value Is  
With A Tolerance  
of +/- 10%



Magnet  
Adsorption Design

Please pay special attention: Baoje provided 5 types of torque adapters have different torque values. Each torque adapter needs to be used with a suitable screwdriver bit to avoid damage to the screw or screwdriver bit.

Installed with magnet

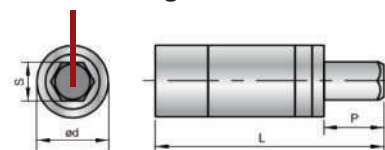

### BJ-ADA-NO-3 /



Item No.	Suit for BAOJE Tool	Suit for BIT	Nm	Ød	S	P	L	N.W.	Contents
BJ-ADA-NO-3	Ø3	H2.0 / H2.5 / TX8	1.2	12	6.35	10	37	80g	1 pc

### BJ-ADA-NO-4 /



Item No.	Suit for BAOJE Tool	Suit for BIT	Nm	Ød	S	P	L	N.W.	Contents
BJ-ADA-NO-4	Ø3 / Ø4	H2.0 / H2.5 / TX9	1.4	12	6.35	10	37	80g	1 pc

### BJ-ADA-NO-5 /



Item No.	Suit for BAOJE Tool	Suit for BIT	Nm	Ød	S	P	L	N.W.	Contents
BJ-ADA-NO-5	Ø5 / Ø6	H2.0 / H2.5 / TX10	2.0	12	6.35	10	37	80g	1 pc

# BJ Torque Screwdriver Kits

## BJ-ADA-NO-6 /



Item No.	Suit for BAOJE Tool	Suit for BIT	Nm	Ød	S	P	L	N.W.	Contents
BJ-ADA-NO-6	Ø5 / Ø6	H2.5 / TX15	3.0	12	6.35	10	37	80g	1 pc

- ▶▶ Please pay special attention: Baoje torque adapter BJ-ADA-NO-6 do not install with the BJ-BIT50-H2.0 screwdriver bit to tighten the M4 screw, because the torque value is too large that might cause the screw and the bit damaged.

## BJ-ADA-NO-8 /



Item No.	Suit for BAOJE Tool	Suit for BIT	Nm	Ød	S	P	L	N.W.	Contents
BJ-ADA-NO-8	Ø8	H2.5 / TX15	3.5	12	6.35	10	37	80g	1 pc

- ▶▶ Please pay special attention: Baoje torque adapter BJ-ADA-NO-8 do not install with the BJ-BIT50-H2.0 screwdriver bit to tighten the M4 screw, because the torque value is too large that might cause the screw and the bit damaged.

## Bits for Torque Screwdriver Characteristic



Hex Screwdriver Bits Can Tighten BJ Toolholder M4 and M5 Screws



TX Screwdriver Bits Can Tighten CNC Inserts Screw



Simple Operation



Magnetic Design



Screwdriver Bit Is Not Loosen During Operation

**Please pay special attention: When using the screwdriver bit, it is important to note that the screwdriver bit and screw with relatively small specifications are not suitable for the use of torque adapter with large torque value, because excessive torque will easily damage the screwdriver bit and screw.**

# BJ Torque Screwdriver Kits

## Product Specification - Hex Screwdriver Bit

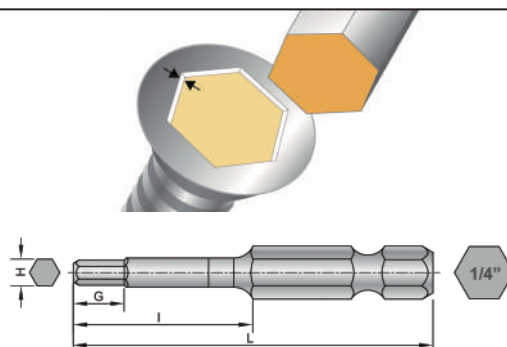

### BJ-BIT50-H2.0

Item No.	Driver Size	Suit for Screw	N.W.	L	Contents
BJ-BIT50-H2.0	H2	M4	53g	50	6 pcs

- ▶▶ Baoje toolholder series that uses M4 screw: BJA-16, BJA-17, BJA-1905, BJA-23, BJA-32, BJN-23, BJJ-16, BJR-22.
- ▶▶ Baoje torque adapters to be used with: BJ-ADA-NO-3, BJ-ADA-NO-4, BJ-ADA-NO-5.
- ▶▶ Please pay special attention: Baoje screwdriver bit BJ-BIT50-H2.0 can withstand maximum torque of 2.0 Nm, use Torque adapter torque value larger than 2.0 Nm will damage the screwdriver bit and the screw.

### BJ-BIT50-H2.5

Item No.	Driver Size	Suit for Screw	N.W.	L	Contents
BJ-BIT50-H2.5	H2.5	M5	58g	50	6 pcs

- ▶▶ Baoje toolholder series that uses M5 screw: BJA-20, BJA-22, BJA-25, BJA-254, BJMA-22.
- ▶▶ Baoje torque adapters to be used with: BJ-ADA-NO-3, BJ-ADA-NO-4, BJ-ADA-NO-5, BJ-ADA-NO-6, BJ-ADA-NO-8.

# BJ Torque Screwdriver Kits

## Product Specification - TORX® TX Screwdriver Bit

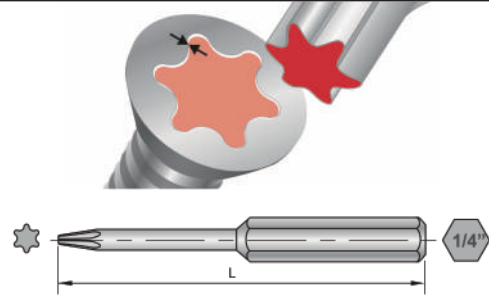

### BJ-BIT50- TX8

Item No.	Driver Size	Suit for Screw	N.W.	L	Contents
BJ-BIT50-TX8	TX8	TORX®	53g	50	6 pcs

▶▶ Baoje torque adapters to be used with: BJ-ADA-NO-3.

### BJ-BIT50- TX9

Item No.	Driver Size	Suit for Screw	N.W.	L	Contents
BJ-BIT50-TX9	TX9	TORX®	55g	50	6 pcs

▶▶ Baoje torque adapters to be used with: BJ-ADA-NO-4.

### BJ-BIT50- TX10

Item No.	Driver Size	Suit for Screw	N.W.	L	Contents
BJ-BIT50-TX10	TX10	TORX®	55g	50	6 pcs

▶▶ Baoje torque adapters to be used with: BJ-ADA-NO-5.

### BJ-BIT50- TX15

Item No.	Driver Size	Suit for Screw	N.W.	L	Contents
BJ-BIT50-TX15	TX15	TORX®	55g	50	6 pcs

▶▶ Baoje torque adapters to be used with: BJ-ADA-NO-6, BJ-ADA-NO-8.

# BJ Torque Screwdriver Kits

## BJ Toolholders Screw Specifications Comparison Table

- ▶▶ Baoje toolholder screw specifications are M4 and M5, when toolholder uses M4 screw, then use H2.0 screwdriver bit, when toolholder uses M5 screw, then use H2.5 screwdriver bit.

BAOJE Toolholder Series	Screw
BJA-16	M4
BJA-17	M4
BJA-1905	M4
BJA-20	M5
BJA-22	M5
BJA-23	M4 (old) / M5 (new)
BJA-25	M5
BJA-254	M5
BJA-32	M4
BJMA-22	M5
BJN-23	M4
BJJ-16	M4
BJR-22	M4 (old) / M5 (new)
BJH	M5
BJZN-E	M4 or M5



**BAOJE Industrial Co.,Ltd.**

No.188,Niaosong 1st St.,Yongkang Dist.,  
Tainan City,Taiwan

TEL 886 6 253 1237

FAX 886 6 211 6567

Email [service@baojetoool.com](mailto:service@baojetoool.com)